

Irrigation Professionals with questions about design or comments concerning this workbook can be directed to Hunter Technical Services at 800-733-2823

© Copyright 2012 by Hunter Industries Incorporated
The Irrigation Innovators

All Rights Reserved

This workbook may not be reproduced in whole or in part by any means (with the exception of short quotes for the purpose of review) without the permission of the publisher

For information on ordering additional Irrigation System Design workbooks or other literature or sales support materials contact:

Hunter Industries Incorporated
1940 Diamond Street
San Marcos, CA 92078 USA

Phone: 760-744-5240

Fax: 800-848-6837

www.hunterindustries.com

ED-004.B F 12/12

Information contained in this workbook is based upon generally accepted formulas, computations, and trade practices. Hunter Industries Incorporated and its affiliates assume no responsibility or liability for errors or for the use of the information contained herein.

Hunter[®]

Irrigation System Design

Introduction	8:00 - 8:15
Plot Plans	8:15 - 8:45
Basic Hydraulics	8:45 - 9:15
Break	9:15 - 9:25
Design Capacity	9:25 - 10:55
Break	10:55 - 11:05
Sprinkler Selection	11:05 - 11:50
Backflow Prevention	1:50 - 12:00
Lunch	12:00 - 12:45
Sprinkler Placement	12:45 - 1:30
Break	1:30 - 1:40
System Lay-out and Pipe Sizing	1:40 - 2:40
Break	2:40 - 2:50
Re-Calculating Friction Losses	2:50 - 3:20
Precipitation Rates	3:20 - 3:40
Irrigation Scheduling	3:40 - 3:50
Q&A/Conclusion	3:50 - 4:00

The above schedule is approximate and is subject to change



Plot Plans

Introduction

One of the most costly mistakes in developing an irrigation system is a poor design stemming from inaccurate plot plan measurements. If the designer has carefully determined the system's design capacity and working pressure at the sprinkler heads, and does not take the same care in obtaining accurate measurements, the irrigation system may fail.

A mistake in the field measurements could mean the difference between an irrigation system with good head-to-head coverage and a system where the heads are stretched out too far. Or, the error could result in lost profits because of having to add heads, pipe, and valves that may not have been covered in the bid.

Designing the System

Designing an irrigation system is a matter of gathering the project's site information and systematically transferring that information to a large sheet of paper, and adding sprinklers, pipes, and valves in the appropriate places. In this section we will discuss the various steps involved in gathering the site information, and completing the design.

First, in order to get accurate information from the site, you will need the proper tools. While it is possible to design a sprinkler system without some of these tools, you will find your job a lot easier with them.

Field Tools

At the project site, you will need to measure the static pressure and obtain the size of the water supply lines, as well as measure the actual property. You will need the following tools in order to accomplish this:

- Pressure gauge with hose adapter
- Tape measure (25 or 30 foot and at least one 100 foot)
- Screwdriver
- String

The pressure gauge should be of high quality, as you must have an accurate pressure measurement if you are to design an efficient sprinkler system. A pressure gauge can be purchased from your distributor.

Measuring a property is a great deal easier and more precise with two or more tapes. The 100 foot tape is used for longer measurements, and can be used in conjunction with your smaller, 25 or 30 foot tape measure to plot out curves, or to make triangulation measurements faster and more accurate. For larger triangulation measurements, two 100 foot tapes used together will make your job a lot easier. (More on triangulation measuring later.)

The screwdriver is used to hold the end of the 100 foot tape measure in place while you unreel the tape and get your dimensions.

The string can be wrapped around the service line and delivery line in order to get the sizes of those pipes. Simply wrap the string around the pipe, measure how long the string is, and then compare to the chart on page 11 of the Hunter Friction Loss Tables (located in the back of this design workbook).

Drawing Tools

There are just a few tools you will need to begin drawing sprinkler systems.

- Compass
- Architect's scale
- Engineer's scale

The compass is used to lightly draw small arcs when locating objects on your plan which were triangularly measured in the field. Additionally, you will use this tool a lot when drawing sprinkler locations.

Of the two scales, you will probably use the Engineer's scale the most. The graph section on the Hunter Design Tablet (LIT-247) measures 10 in. by 15 in., so using the 20 to 1 on the Engineer's scale (or 20 ft. equals 1 in.), you can draw a property as large as 200 ft by 300 ft.. Using the 10 scale, you can draw a property as large as 100 ft by 150 ft.

Other drafting tools are available, and as you gain more experience in sprinkler system design, you may want to explore the use of some of these other tools to draw your systems. Some of the more common tools include:

- T-square
- 45° triangle
- 30°/60° triangle
- Circle template
- French Curve
- Drafting board
- Erasing shield

Sketch the Property

The first step in designing an irrigation system is obtaining accurate field measurements. Later, you will need to know how much water you have available, and at what pressure. Additionally, once you leave the project with your measurements, you don't want to have to go back to check measurements or to get a measurement that you forgot to get the first time.

Start by sketching the property on a large piece of paper. Include the approximate location of property lines, buildings, all hardscape, trees, shrubs, lawns, grade changes, etc. Once this is complete, you can begin to record the appropriate site information and measure the property.

Record Site Information

Connect the pressure gauge to a hose faucet, open the faucet and record the static pressure on the sketch. Be sure there is no other water running on the property while you are performing your test. Because pressure can vary a great deal throughout the day, try to measure the pressure as close to the planned watering time as possible.

Record the size of the water meter on your sketch; the size is stamped on the top of the meter.

Later, when you are calculating working pressure, you will need a reasonably accurate estimate of elevation change between the point where you measured the static pressure, and where you will make the sprinkler system tie-in (POC), so be sure to record this distance on your sketch. You will also need to record the elevation change from the POC to the proposed location of the highest head on the system.

To determine service and delivery line size, wrap a string around the service line and delivery line, then measure how long the string is, and compare your measurement to the chart below. (This chart can also be found on page 11 of the Hunter Friction Loss Tables. The tables are located in the back of this design workbook). PVC pipe is the same outside diameter as clean galvanized pipe. Be sure to record these measurements on your sketch.

Length of String	2 3/4"	3 1/4"	3 1/2"	4"	4 3/8"	5"
Size of Service Line - Copper	3/4"		1"		1 1/4"	
Size of Service Line - Galvanized		3/4"		1"		1 1/4"

Figure 1

Measure and record the approximate length of the service line. This is the line that runs from the city water main to the water meter (or curb stop if the property doesn't have a meter).

Then measure the length of the delivery line, or the pipe that runs from the meter to the proposed sprinkler system point of connection (POC) location. Record the length of pipe and the proposed POC location.

Measure the Property

Take careful measurements and add them to your sketch.

When measuring property lines, use the house as a reference, sighting down the sides of the house walls:

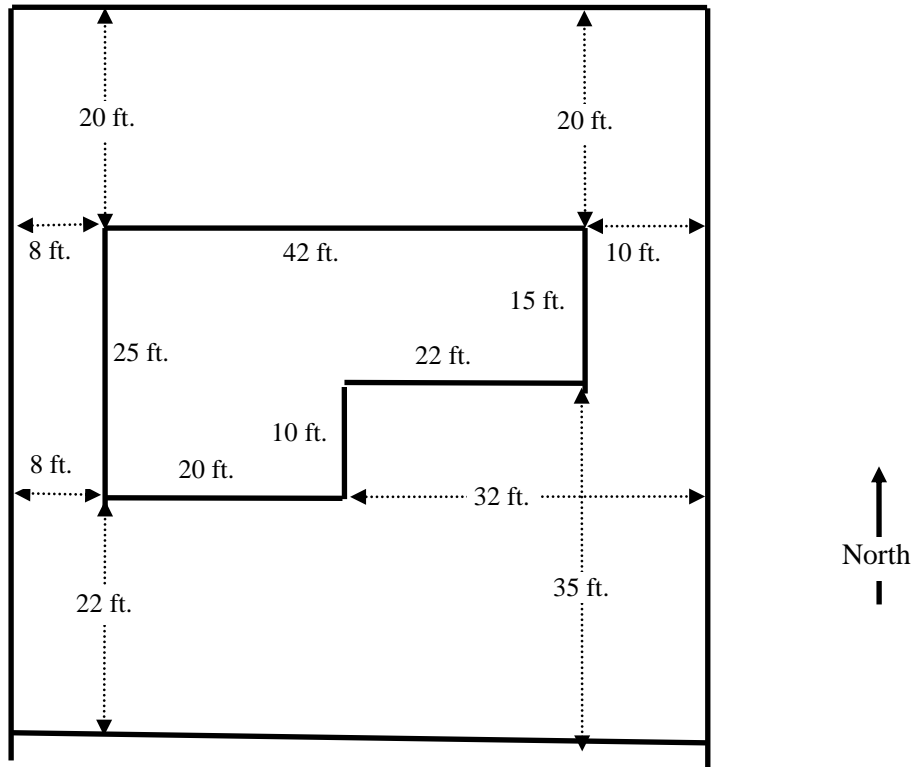

Figure 2

The difference between the length of the East property line (67 ft.) and the West property line (70 ft.) is only 3 feet. But where is that 3 foot difference? Using this method of measurement, you can quickly see that it is not in the back yard, but in the front.

If you had just looked at the over-all job site you would have said the property is a rectangle with the opposite sides of the property are equal lengths. And then based on that observation, if you just measured the East and the North property lines and designed the sprinkler system according to a rectangular property, the sprinklers in the Southwest corner would not have head to head coverage.

You could change the nozzle sizes and probably reach the additional 3 feet, but that may cause the system to exceed design capacity, so you may need to add a valve, add pipe, and install a larger controller than what you included in your bid.

You can see how sighting down the line of the wall of a house, then continuing that imaginary line to the property line, and finally measuring the distance from the house to the property line along that imaginary line can be a very accurate way to set the house on the property. At the same time, this method establishes the right locations for the property lines, and ultimately the right locations for the sprinkler heads.

For curving sidewalks or driveways, or meandering lawn edges, sighting down the side of the house is an excellent way of getting an accurate layout.

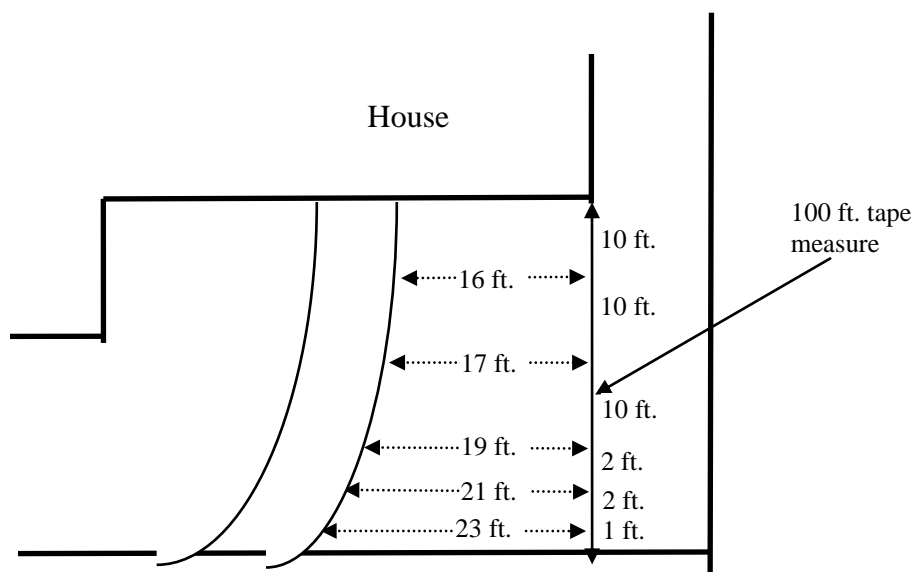

Figure 3

Lay out one of your 100 foot tapes along the imaginary line (the extension of the side of the house). Then measure across at a right angle to the tape measure from the imaginary line to the curve you need located. Depending on how tight a curve it is, you may want to get a measurement every 5 feet, or every 10 feet. If the curve is really tight, you might even want to get more measurements, while if it is a gentle curve, you might want fewer measurements.

Trees, water meters, and other items on your sketch which are standing alone can be located by taking a measurement from two other items such as two separate corners of a building and forming a triangle with the tree or other object you are trying to locate.

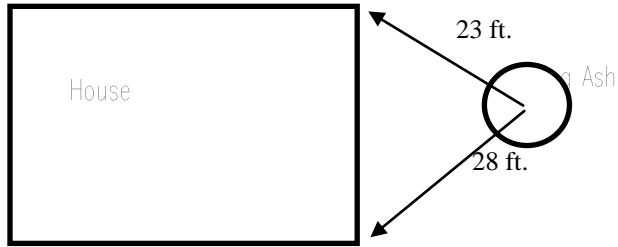

Figure 4

If your project has a slope or rolling terrain, remember that the plan view, or the “bird’s-eye view” will show the slope as being shorter than the actual soil measurement. You will want to take this into consideration when measuring the site and drawing your sketch.

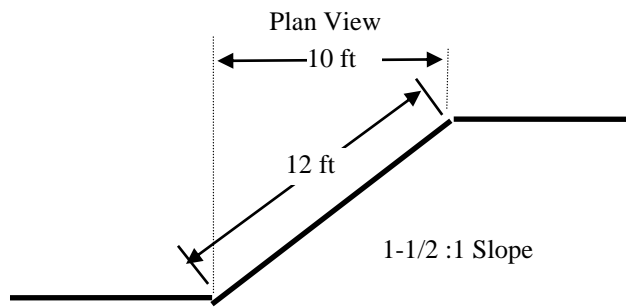
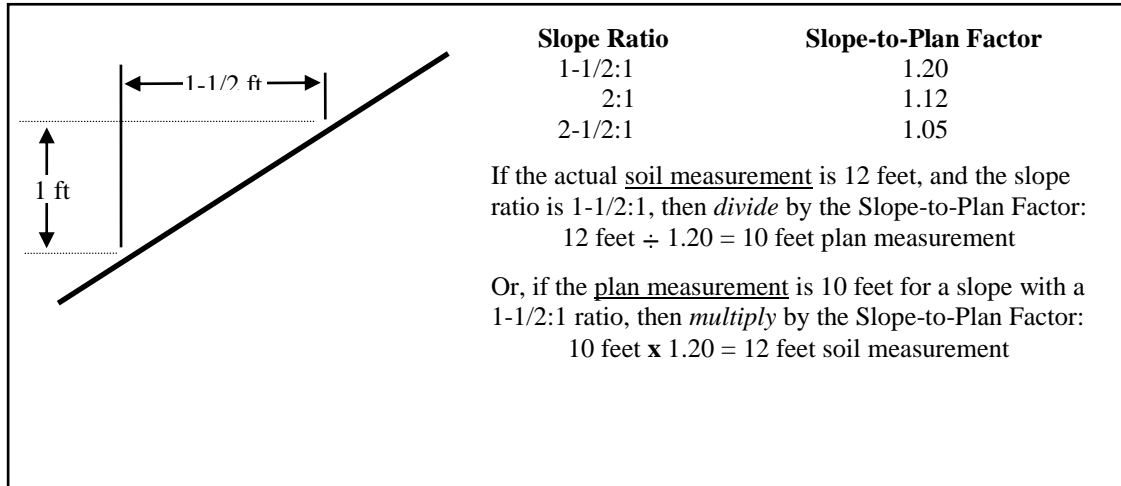

Figure 5

In Figure 5, the slope is referred to as a 1-1/2 to 1 slope. This means that you must measure out 1-1/2 foot in order to record a 1 foot drop.



Step 2 - Redraw On Graph Paper

The next step is to redraw your sketch on graph paper. Be sure the drawing is large enough to read, is positioned correctly, and fits on the paper.

Using your drafting scale, see which scale will provide the largest drawing possible. (Generally, the 10 or 20 scale works fine.) In the drawing in figure 2, the longest property line is 70 feet, so you would first try the 10 scale and see if the 70 foot property line will fit on the paper. If when using the 10 scale the property won't fit, try the 20 scale.

Normally, you would want to position the property on the drawing so that the North arrow is pointing up (North would be at the top of the page), and the title block on the graph paper is to the right. In some cases, the property will be very narrow and long with the North arrow running parallel to the long property line. In a case such as this, you may have to turn the property so that the North arrow is pointing side-ways in order to use a scale where the drawing will be legible.

Be sure to transfer all of the information on your sketch to the new drawing, including the house, property lines, driveway, trees, shrubs, patios, decks, lawns, lamp posts, fences, walls, walkways, etc.

Once you have transferred the site information you will have a completed plot plan on which you will be able to design your system. On the new drawing, divide the property into areas. The areas should be as large as possible, while considering the different watering needs of lawns and shrubs in sunny or shady areas.

Step 3 - Select and Place Sprinklers

You are now ready to begin selecting and placing sprinklers in the established areas. While there will be a thorough discussion of selecting and placing sprinklers in two later sections, here is an overview of the process:

Selecting Sprinklers

Sprinkler selection is a matter of wading through the various sprinkler characteristics and choosing the sprinkler that best suits the area you wish to water. This information is found in the product catalog.

Information that will be important in your selection includes the sprinkler's operating pressure, flow range, and precipitation rate, and its radius and arc of coverage. Additionally, each sprinkler has special features (such as built-in check valves, side inlets, angles of trajectory) which may be an instrumental part of the selection process.

Placing Sprinklers

Begin placing sprinklers on the plan one area at a time. Start by placing the sprinklers in the corners of the area. Be sure to draw the sprinkler's arc of coverage to insure head-to-head coverage.









To draw the sprinkler's arc of coverage, set your compass to the recommended radius according to the scale of the plot plan, and with the pointed end on the location of the sprinkler, draw an arc. This arc should touch or go beyond the sprinkler next to it in order to achieve head-to-head coverage. If the arc does not reach the next head, add sprinklers along the perimeters. Then, if necessary for full coverage, add sprinklers in the middle.

Symbols

In order to distinguish between the sprinklers and valves and the other products that you will be placing on the plan, you will need to draw different symbols designating the various items.

The American Society of Irrigation Consultants (ASIC) and the American Society of Agricultural Engineers (ASAE) have both proposed standardized symbols for landscape irrigation. The irrigation industry, however, has been reluctant to accept any set of standard symbols for irrigation design.

Because of a lack of standardized symbols, many designers use some of the proposed symbols along with symbols they have designed. In the case of sprinkler heads, some designers have adopted a system of a circle with an number inside. This works particularly well where sprinklers have multiple nozzle options. The following are some suggestions for typical symbols:

Sprinkler Heads	Quarter	
	Half	
	Full	
Automatic Control Valves		
Isolation Valves		
Controller		
Lateral Line Pipe		
Main Line Pipe		

Symbols, no matter who designs them, should be easy to draw by hand, and should be easily distinguishable from one to another.

Step 4 - Group Sprinklers Into Zones

After you have selected and placed the sprinklers, you will need to group them by area into zones based on the system's design capacity.

The Design Capacity section of this Design workbook will provide you with information on system capacity, and the System Layout section will explain how to use that information to divide the area into separate sprinkler zones.

To group the sprinklers into zones, write individual sprinkler GPM requirement next to each sprinkler in the area. Add up the GPM requirements for all sprinklers in one area, and divide by the total GPM so that the design capacity is not exceeded.

After the individual sprinkler zones have been established, connect the sprinklers together with pipe, size the pipe, and layout and size the valves and backflow preventer.

Step 5 - Size Pipe and Recalculate Friction Losses

To size the pipe, start at the last head on the zone and note the GPM requirement for that head. Refer to the Hunter Friction Loss Tables for the type of pipe you are using. Size the pipe according to the chart, then move to the next pipe.

Add the GPM requirements of the next head to that of the last head on the system together to size the pipe supplying the two heads.

To size the next pipe, add the GPM requirement of the next head to the last total. Continue to do this until you get to the zone valve. Be sure to not size a pipe smaller than the chart indicates.

After the pipes in all of the zones in all areas have been sized, refer to the pressure loss chart in the product catalog for the valve you are using. Size the valve according to those charts. Then size the main line pipe according to the amount of flow needed by the zone control valves.

When you have completed the layout and pipe sizing, go back over your design and calculate the friction loss on the most critical zones. A thorough discussion of friction loss calculations is discussed in the Friction Loss section.

More information on pipe layout and sizing is available in the System Layout section.

Step 6 - Finalize Plan

The logo for Hunter, featuring the word "Hunter" in a bold, black, sans-serif font. A registered trademark symbol (®) is located at the top right of the letter "r".

Make sure the drawing is dated and if any changes are made, be sure the date with a brief statement of those changes get noted on the plan. If your final drawing includes more than one page, include the page numbers with the total number of pages on all sheets (1 of 1, 1 of 3).

Irrigation designers will want to also include the following items on their plans:

- Installation details (Hunter LIT-141)
- General and specific installation notes
- Requirements for design or specification changes
- Statement of design capacity and working pressure, for example: “This design is based on ____ PSI at ____ GPM.”

Summary

The importance of an accurate irrigation plan cannot be over stated. An inaccurate design could mean poor coverage or lost profits. In addition to accuracy, the completed design should be neat and include all information.

Hunter®

What You Need to Know

While no two designers will develop a drawing the same, the following step-by-step outline will help you in completing your sprinkler system designs.

Step 1 - Sketch Property

- Sketch the property on a piece of paper
- Place the house location on your sketch
- Draw all concrete or brick walks, patios, and driveways
- Include wood decks and their approximate height above grade
- Locate walls and fences on the sketch, and note their heights
- Mark the lawn areas and the locations, types, and sizes of all trees and shrubs
- Note the location of severe grade changes
- Be sure to include plenty of measurements
- Note the direction of North on your sketch
- Take a static PSI measurement and write it on the sketch
- Note the location of the water meter
- Write down the sizes and the types of pipe for the service and delivery lines
- Note where you will probably make your Point of Connection (POC)

Step 2 - Redraw On Graph Paper

- On a separate sheet of paper, re-draw your sketch to scale
- Be sure to include all walks, patios, decks, driveways, and landscape
- Write the scale you are using on the plan; you do not need to include measurements
- Place the North arrow on the plot plan
- Group like-landscape areas together

Step 3 - Select and Place Sprinklers

- Select sprinklers
- Begin placing sprinklers on the plan one area at a time
- Start with placing sprinklers in the corners
- Draw sprinkler coverage arcs to insure head-to-head coverage
- Add sprinklers along the perimeters to obtain head-to-head coverage
- Add sprinklers in the middle if necessary

Step 4 - Group Sprinklers Into Zones

- Group sprinklers into zones
- Draw a line connecting all sprinklers on each zone
- Determine valve manifold locations
- Draw a line connecting the sprinklers to zone valve
- Add the main line connecting the valves to the backflow preventer and the POC

Step 5 - Size Pipe and Recalculate Friction Losses

- Size the pipes
- Start at the last head on the zone
- Size the pipe between each head adding the GPM requirements as you go
- Calculate the friction loss on the most critical zones

Step 6 - Finalize Plan

- Add the irrigation legend to the plan
- Include any installation or other important notes
- Complete the title block

On-Site Checklist

- ◇ Location of trees, shrubs, other obstructions
- ◇ Static Water Pressure
- ◇ Water Meter Size
- ◇ Elevation Change - from location of the static pressure measurement to the POC
- ◇ Elevation Change - from the POC to the where the highest head will be located
- ◇ Service Line Size, Length, and Type of Pipe
- ◇ Delivery Line Size, Length, and Type of Pipe
- ◇ Site Measurements for Plot Plan
- ◇ Location for POC
- ◇ Location of 115 Volt Electrical (for controller)
- ◇ Slope Locations (note elevation changes)
- ◇ Soil Type(s)
- ◇ North Orientation
- ◇ Direction of Prevailing Wind
- ◇ Landscape and Hardscape Plan
- ◇ Review Local Code Requirements

Basic Hydraulics

Introduction

Hydraulics is defined as a branch of science that deals with the effects of water or other liquids in motion. In this section we will study characteristics of water – both in motion and at rest. The emphasis will be on the relationships between flow, velocity, and pressure. With this knowledge we will be able to determine pressure losses in pipe and fittings, and pressures at various points in an irrigation system.

A knowledge of the basic principles of irrigation hydraulics is essential to designing and maintaining an economical and efficient irrigation system. Understanding the principles outlined in this section will lead to irrigation systems that have a more uniform distribution of water and cost less to install and maintain.

How Does Hydraulics Affect an Irrigation System?

Water pressure in an irrigation system will affect the performance of the sprinklers. If the system is designed correctly, there will be enough pressure throughout the system for all sprinklers to operate properly. Maintaining this pressure in the system will help to ensure the most uniform coverage possible. While a consistent pressure is the primary goal, it is important to achieve this at the lowest cost. With a knowledge of hydraulics, it is possible to design a system using the smallest and therefore least expensive components while conserving sufficient pressure for optimum system performance.

Water Pressure

Water pressure in irrigation systems is created in two ways: 1) by using the weight of water (such as with a water tower) to exert the force necessary to create pressure in the system or 2) by the use of a pump (a mechanical pressurization).

In many municipal water delivery systems both of these methods may be used to create the water pressure we have at our homes and businesses. Water tanks use gravity to create pressure. These tanks are located on a mountain top, tower or roof top. Because these storage tanks are located above the homes they serve, the weight of the water creates pressure in the pipes leading to those homes. In other cases, a “booster” pump is used to increase the pressure where the elevation of the water storage tank is not high enough above the home to provide sufficient pressure. In other areas, the water source may be a well, lake or canal with a pump generating the pressure.

In this section, we will explore how water pressure is affected by its weight and what happens to water pressure when water moves through irrigation pipes.

Water pressure can be measured or expressed in several ways:

- 1) psi; the most commonly used method in landscape irrigation, pounds of pressure exerted per square inch,
- 2) feet of head; equivalent to the pressure at the bottom of a column of water 1 ft. high [in this case the unit of measurement is feet of head (ft./hd)].

How Pressure is Created By the Weight of Water

What water weighs at 60° F:

- 1 cubic foot (ft.³) or 1728 cubic inches (in.³) of water = 62.43 lb.
- 1 cubic inch, (in.³) of water = 0.0361 lbs.

Water creates pressure in landscape irrigation systems by the accumulated weight of the water.

In Figure 6, we can see a container 1 ft. high and 1 ft. wide, holding 1 ft.³ of water, would create a column of water 1 ft. high over every square inch on the bottom of the container.

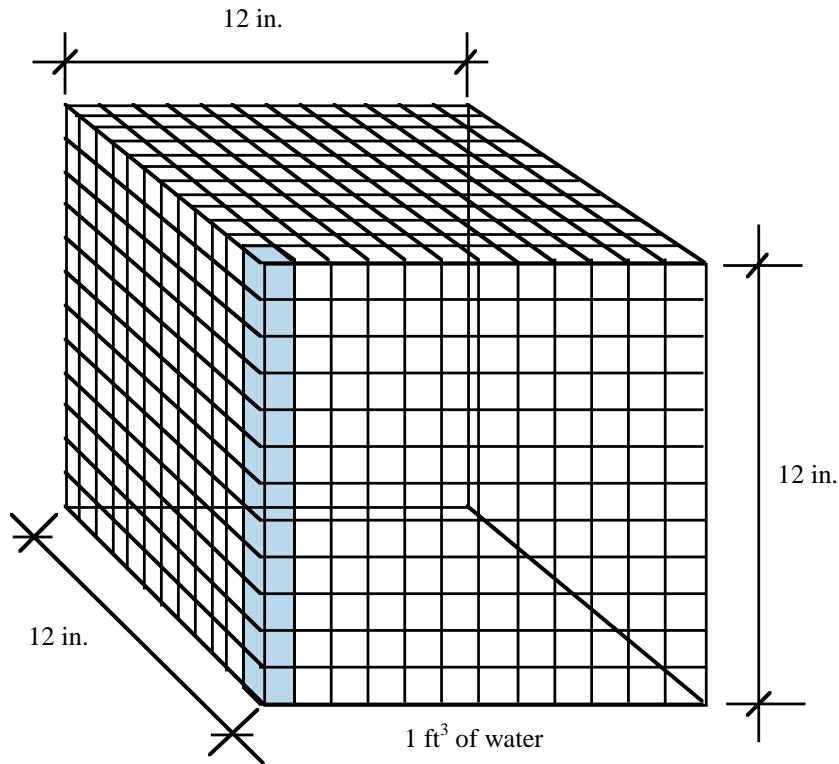

Figure 6

If we look at just one of those columns, Figure 7, we can calculate the weight of water pressing on the bottom of the column in pounds per square inch (PSI).

A column 12 in. high resting on a surface at the bottom of 1 in.² represents a column with 12 in.³ of water.

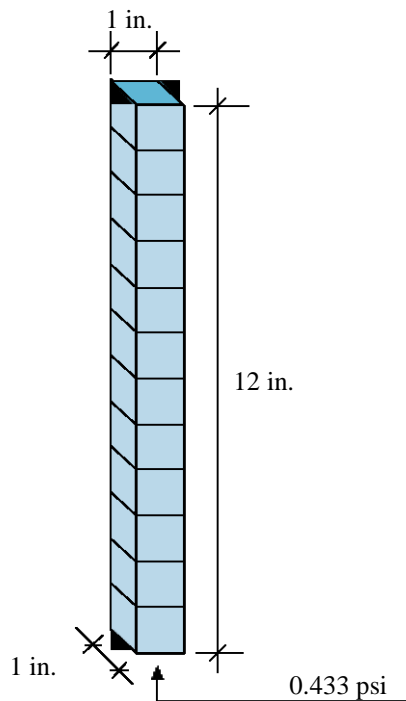

Figure 7

The weight of the 12-in.-high column of water is 0.433 lbs. ($12 \text{ in.}^3 \times 0.0361 \text{ lbs. per in.}^3 = 0.433 \text{ lbs.}$). Therefore, a column of water 1 ft. high will exert a pressure at the bottom of 0.433 lbs. per in.² or 0.433 PSI. This is a very **important number** because it means that as our column of water gets higher, **every 1 ft. of height added will increase the pressure at the bottom by 0.433 PSI.**

For example, a column of water 2 ft. high creates a pressure at the bottom of 0.866 PSI ($0.433 \text{ PSI/ft.} \times 2 \text{ ft.} = 0.866 \text{ PSI}$).

Important Facts

This gives us some important facts to remember. **Memorize these facts:**

- A column of water 1 ft. high = 1 foot of head = 0.433 PSI.
- 1.0 PSI equals the pressure created by a column of water 2.31 ft. high, or
1 PSI = 2.31 ft. of head (ft./head).
- A column of water 1 ft. high creates 0.433 PSI at the bottom,
or
1 ft./head = 0.433 PSI.

Does the Shape or Size of the Container Make a Difference?

The shape or size of the container does **NOT** make any difference in the pressure at the bottom, as seen in Figure 8. Because we are measuring the weight of water in a column resting on 1 in² regardless of the container's size or shape, pressure at **an equal depth** will be the same no matter what the shape or size of the container.

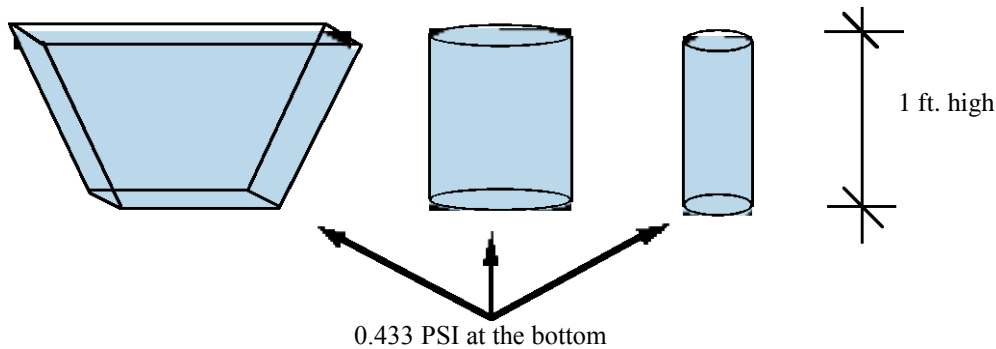

Figure 8

While at first this does not seem possible, let's look at the example in Figure 9 that will help us to better understand this concept. Consider diving into a swimming pool or lake. When you dive below the surface of a lake or pool, the deeper you dive the more pressure builds up on your ears. The amount of increased pressure on your ears does not change with the shape of the pool nor does it change depending on whether you are diving into a backyard pool or a large lake. The pressure at any depth in that pool or lake is dependent upon the **height** of the column of water above that point - not on the shape or size of the pool.

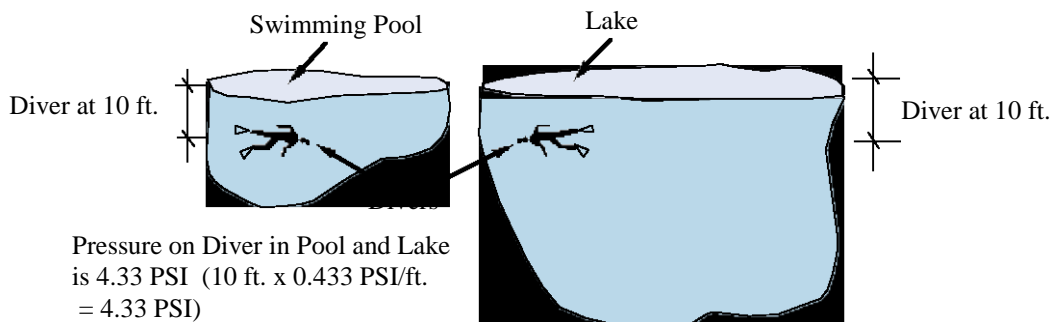

Figure 9

What Does This Mean in Irrigation Design?

When designing landscape irrigation systems, for every 1 ft. of elevation change there will be a corresponding change in pressure of 0.433 PSI.

Static and Dynamic Pressure

There are two classifications of water pressure:

static and **dynamic** pressure:

- **Static pressure** is a measurement of water pressure when the **water is at rest**. In other words, the water is not moving in the system.
- **Dynamic pressure** (or working pressure) is a measurement of water pressure with the **water in motion** (also known as working pressure).

Factors Affecting Static Pressure

Static pressure is created either by elevation change or by a pump. In this section, we will concentrate on the effect of elevation change on static pressure. As previously discussed, each foot of elevation change results in a 0.433 PSI change in pressure. As we can see in the following diagrams, the change in elevation that we are concerned with is the change in **vertical** elevation only, not in the length of pipe. Because water exerts pressure equally in all directions, the **length** of pipe will not affect the **static** pressure (it does affect the dynamic pressure, as we will see later).

If we return to our tank of water, Figure 10, we can see that inserting a fourteen foot pipe into the tank of water at an angle does not affect the pressure at the bottom of the tank or pipe. **Static** pressure is not affected by the length of the pipe, only by elevation change.

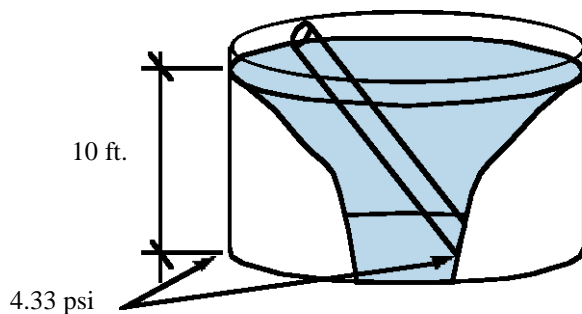

Figure 10

We can see the effect of elevation change on static pressure in an irrigation system in Figures 11 and 12. In the example in Figure 11, the static pressure at the water meter is 60 PSI. Since the control valve is below the water meter by 8 ft., the static pressure is increased by 3.46 PSI. (8 ft. x 0.433 PSI per foot = 3.46 PSI).

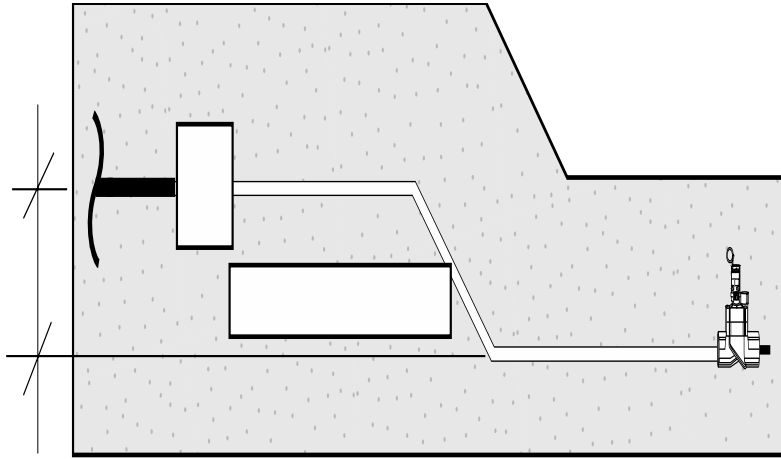

Figure 11

$$8 \text{ ft.} \times 0.433 \text{ PSI/ft.} = 3.46 \text{ PSI}$$
$$60 \text{ PSI} + 3.46 \text{ PSI} = 63.46 \text{ PSI static pressure}$$

Going uphill **reverses** the process: for every 1 ft. of vertical elevation gain the static pressure will drop by 0.433 PSI.

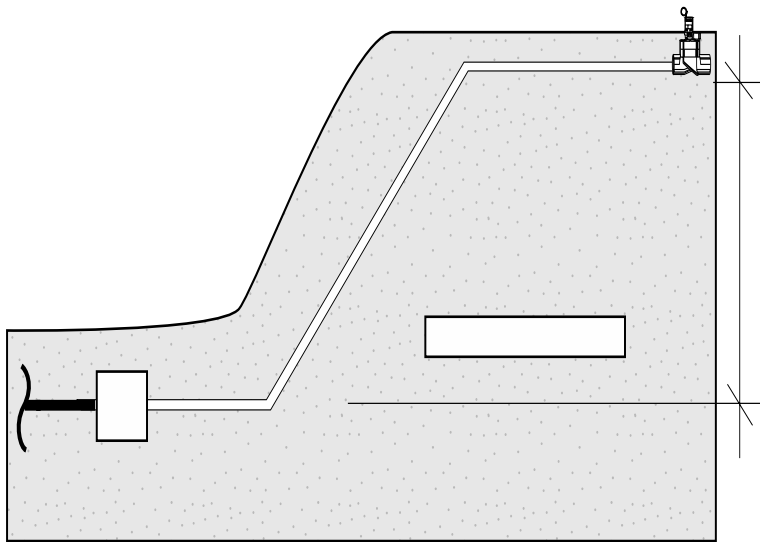

Figure 12

$$40 \text{ ft.} \times 0.433 \text{ PSI/ft.} = 17.32 \text{ PSI}$$
$$60 \text{ PSI} - 17.32 \text{ PSI} = 42.68 \text{ PSI static pressure}$$

Static pressure is not affected by the size or length of pipe. Both diagrams in Figure 13 illustrate a control valve 40 ft. above a water meter. In the first case the main line from the meter to the valve is 100 ft. of two inch pipe and in the second it is 250 ft. of one inch pipe. The **static** pressure at each control valve is 42.68 PSI. Only the **vertical elevation** change affects the static pressure.

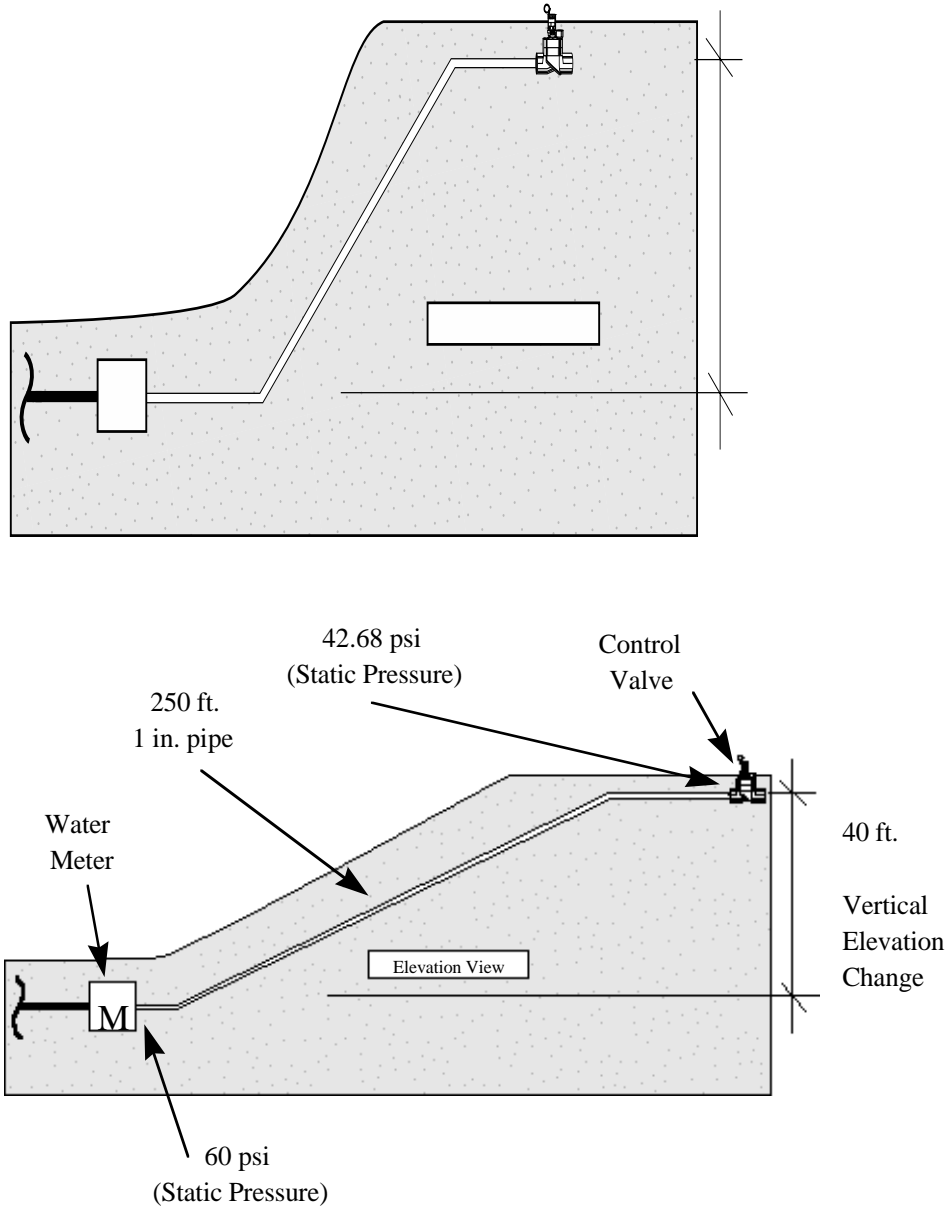

Figure 13

Factors Affecting Dynamic Pressure

When water moves through an irrigation system it is said to be in a dynamic state. The movement of water is described in terms of **velocity** (the speed at which it is moving) and **flow** (the amount of water moving through the system). The velocity is measured in feet per second (fps) and the flow is measured in gallons per minute (GPM). Dynamic water pressure is measured in the same units as static pressure (PSI).

Dynamic pressure is affected by the following factors:

- 1) change in elevation (change in elevation affects static and dynamic pressure in the same way)
- 2) friction losses in pipe, valves and fittings (pressure loss is caused by water moving through the system)
- 3) velocity head (the pressure required to make water move within the system; this is a minor loss and won't be calculated here)
- 4) entrance losses (the pressure lost as water flows through openings; this is also a minor loss and won't be calculated here)

Friction Loss in Pipe

When measuring dynamic pressure at any point in a landscape irrigation system, we must first determine the static pressure at that point and then subtract the pressure losses due to the movement of water.

As water moves through an irrigation system, pressure is lost because of turbulence created by the moving water. This turbulence can be created in pipes, valves or fittings. These pressure losses are referred to as “**friction losses.**”

There are four factors that affect friction losses in pipe:

- 1) the **velocity** of the water,
- 2) the **inside diameter** of the pipe,
- 3) the **roughness** of the inside of the pipe and
- 4) the **length** of the pipe.

VELOCITY is the speed at which water moves through the system and it is measured in **feet per second** (fps). Water moving in the pipe causes turbulence and results in a loss of dynamic pressure. Increasing the velocity will cause increased turbulence and increased pressure losses. **In Figure 14 the inside diameter, roughness and length remain the same.** However, due to increased velocity (fps), there is a greater dynamic pressure loss. [Note: With the increase in velocity there is a corresponding increase in flow (GPM). Velocity and flow are directly related. An increase or decrease in one will result in a corresponding increase or decrease in the other.]

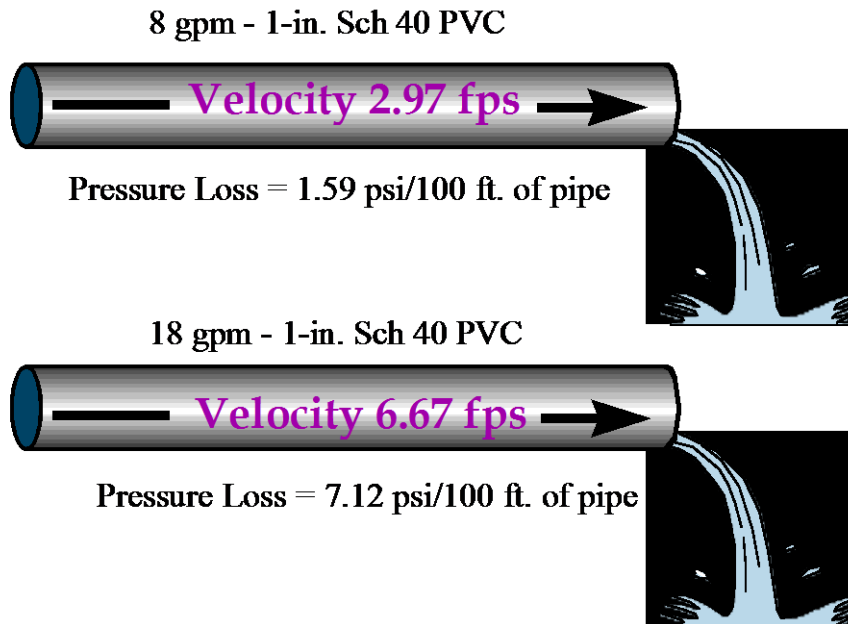

Figure 14

When velocity increases, pressure loss increases. When the velocity is increased from 2.97 fps to 6.67 fps, the pressure lost in 100 ft. of pipe increases from 1.59 PSI to 7.12 PSI. The velocity typically increases when 1) the flow is increased, such as when additional sprinklers are added to an existing line or 2) a smaller pipe is used with the same flow (GPM).

INSIDE DIAMETER (i.d.) of the pipe: a smaller inside pipe diameter proportionally increases the amount of water in contact with the pipe surface. This increased contact **increases** the turbulence and consequently **increases** the dynamic pressure loss. In Figure 15, the velocity, length and roughness remain the same but the inside pipe diameter is reduced. The reduced i.d. results in increased turbulence and reduced dynamic pressure.

(Note: The velocity remains the same even though the pipe size is reduced because there is a corresponding reduction in the flow.)

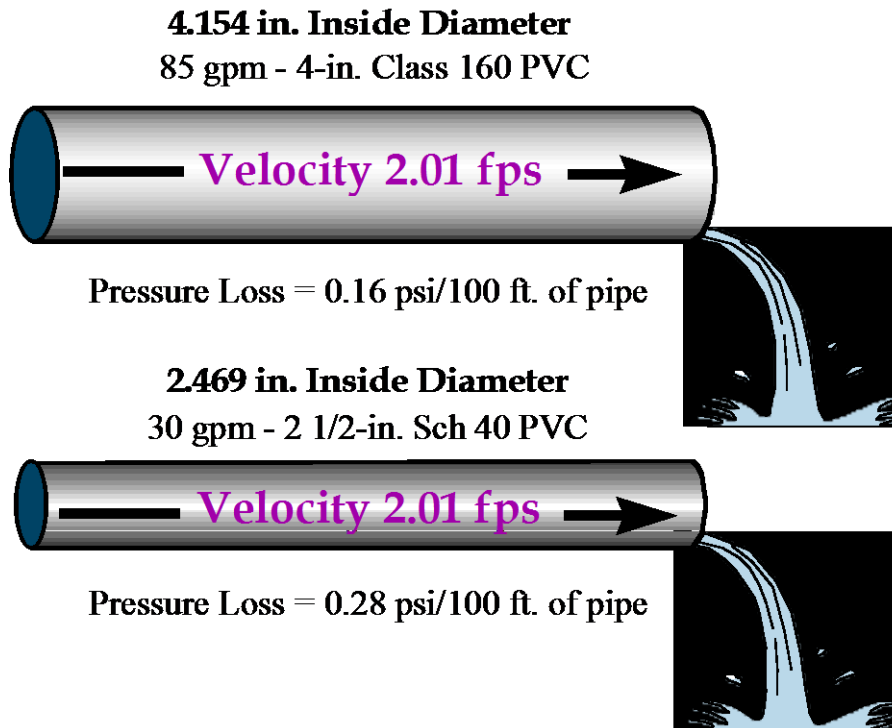

Figure 15

Even with a smaller flow and the same velocity more turbulence was created in the small pipe because there was a greater percentage of the water in contact with the surface.

ROUGHNESS of the inside wall of the pipe is the third factor that affects friction loss in pipe. Pipe wall roughness is rated by a “C” factor. The lower the value of C, the rougher the inside wall of the pipe (in standard steel pipe C=100; in PVC pipe C=150.) The **rougher** the inside, the **more turbulence** created and the **greater** the pressure loss.

In Figure 16, the velocity, volume and inside diameter remain the same. As the roughness of the inside of the pipe increases (standard steel has a rougher pipe wall than PVC), there is an increase in turbulence, resulting in a greater pressure loss.

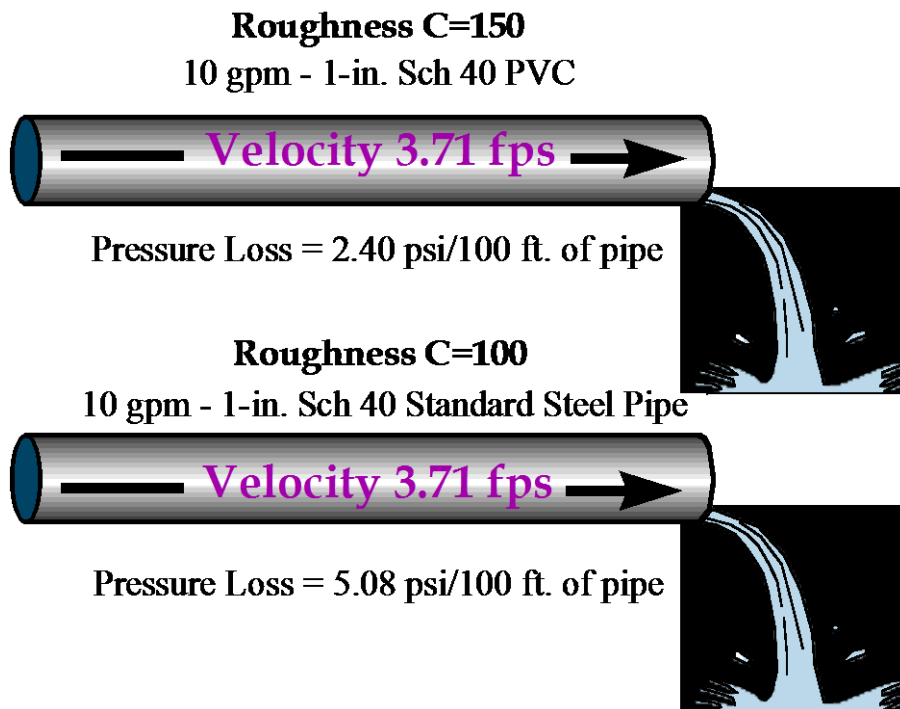

Figure 16

LENGTH is the fourth factor affecting friction losses in pipe. The greater the distance, the greater the cumulative effect of the first three factors (velocity, i.d. and roughness). In Figure 17 we see the direct relationship between increased length and increased pressure loss. The total pressure loss doubles as the length of the pipe doubles.

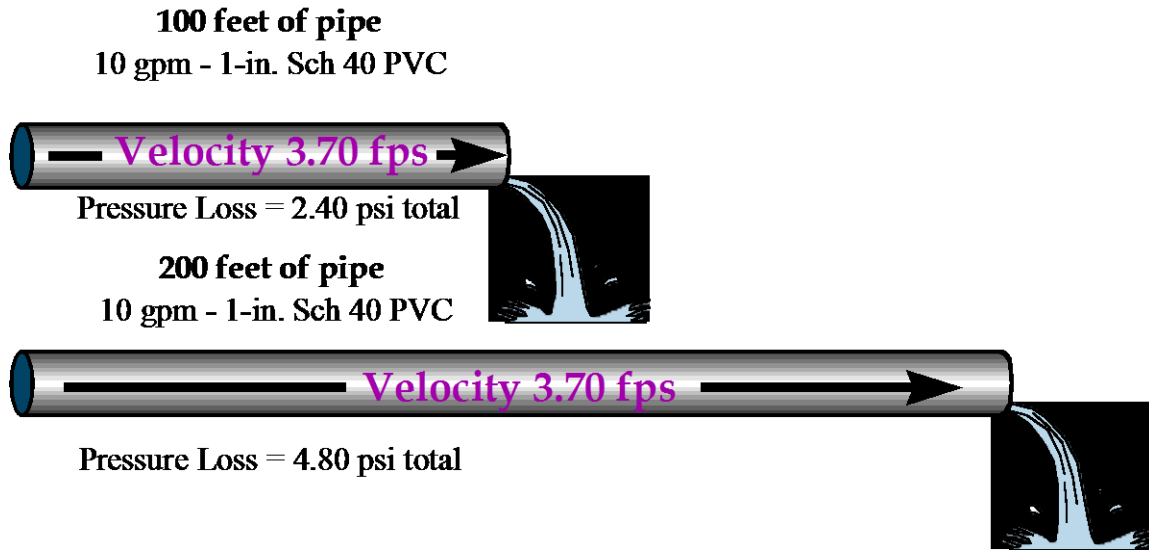

Figure 17

These four factors affecting pressure loss in pipe were used to develop formulas for calculating the pressure loss associated with various types of pipe. Several formulas were developed; the most common in landscape irrigation hydraulics is the **Hazen-Williams** formula. The Hazen-Williams formula can be represented as:

$$H_f = 0.090194 \left(\frac{100}{C} \right)^{1.852} \frac{Q^{1.852}}{d^{4.866}}$$

Where H_f = pressure loss in pounds per square inch (PSI)

C = roughness factor

Q = flow in gallons per minute (GPM)

d = inside pipe diameter in inches

Since these formulas are somewhat cumbersome, we will rely on charts developed using the Hazen-Williams formula. Samples of these charts can be found in the back of this design manual.

Use of Pressure Loss Charts

Figure 18 below represents a portion of one of the pressure loss charts taken from the Hunter Friction Loss Tables found in the back of this design manual.

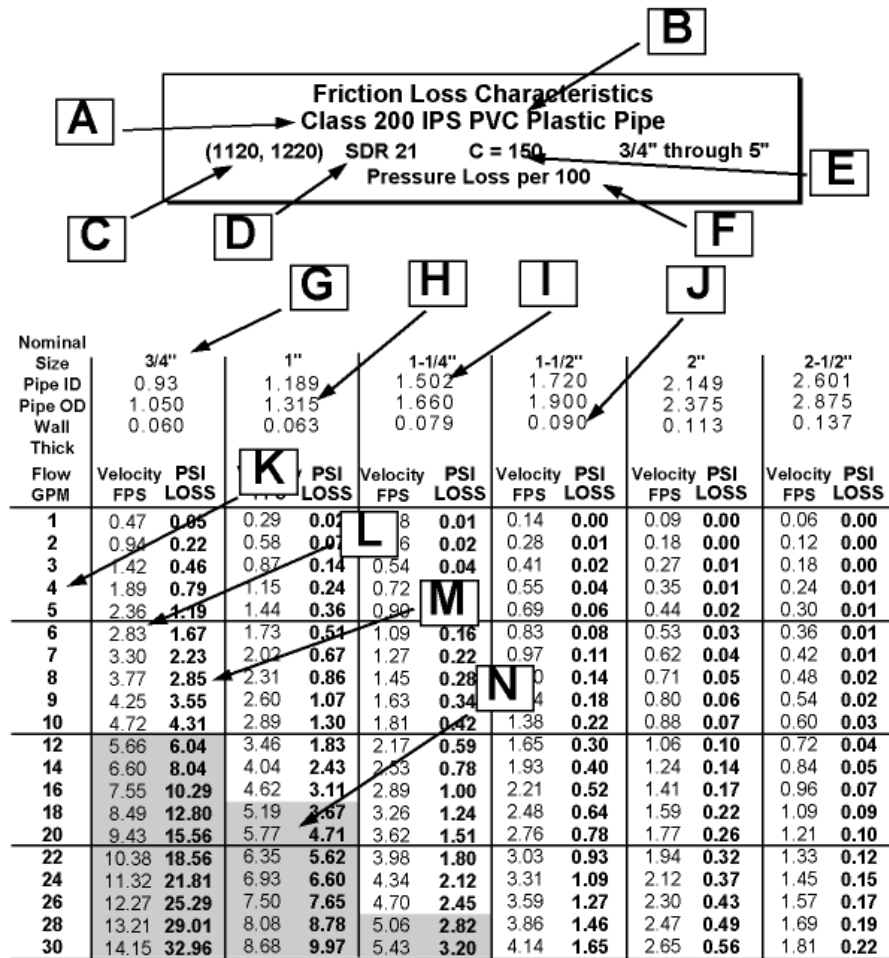

Figure 18

The components of the typical friction loss chart are described below:

- A) Type of pipe represented in the chart.
- B) IPS - Iron Pipe Size - indicates that the pipe's outside diameter dimensions correspond to that of iron pipe. All IPS PVC pipe of the same nominal size will have the same outside diameter. For example: all 1/2-in. PVC irrigation pipe will have an outside diameter of 0.840 in.; thus all 1/2-in. slip fittings will fit on the outside of all types of 1/2-in. PVC pipe.
- C) (1120, 1220) - Represents a designation for the specifications of the plastic pipe.

- D) SDR –Standard Dimension Ratio – indicates the pipe’s wall thickness as a ratio of the outside diameter. Outside diameter of 1-in. pipe is 1.315 in. If you divide 1.315 by the SDR, 21, it will give you a minimum wall thickness. (There may be some exceptions to this rule.) Minimum wall thickness for 1-in. Class 200 PVC pipe $1.315/21=0.063$ in. Class-rated pipes (SDR pipes) maintain a uniform maximum operating pressure across all pipe sizes. This is not true of schedule rated pipes such as Schedule 40 PVC. In schedule rated pipes the maximum operating pressure decreases as pipe size increases.
- E) C=150 – indicates the value of the C factor, which is a measure of the roughness of the inside of the pipe. The lower the number, the rougher the inside of the pipe and the greater the pressure loss. For PVC, C = 150; Galvanized Pipe C = 100.
- F) Designated pressure losses shown in the chart are per 100 ft. of pipe.
- G Size – indicates the “nominal” pipe size. Nominal means “in name only,” and none of the actual pipe dimensions are exactly that size. For example, in the $3/4$ -in. pipe, none of the dimensions are actually $3/4$ -in.
- H) OD – outside pipe diameter in inches.
- I) ID – inside pipe diameter in inches.
- J) Wall Thick – wall thickness in inches.
- K) Flow (GPM) – flow rate in gallons per minute.
- L) Velocity (fps) – speed of water in feet per second at the corresponding flow rate.
- M) PSI Loss – pressure loss per 100 ft. of pipe in pounds per square inch at the corresponding flow rate.
- N) The shaded area on the chart designates those flow rates that exceed 5 fps. It is recommended that caution be used with flow rates above 5 fps in main lines where water hammer will be a concern.

What the Charts Are Used for

These charts are used to:

- Determine the pressure loss in pipe due to friction losses
- Determine the velocity at various flow rates
- Use pressure losses and/or velocities to determine appropriate pipe sizes (pipe sizing is covered in another section)

How to Use the Friction Loss Charts to Calculate Loss in a Specific Length of Pipe

Using the Hunter Friction Loss Tables in the back of this design manual:

1. Find the flow of water in gallons per minute (GPM) in the column on the left.
2. Now read across the top of the chart looking for the size of the pipe.
3. Read down this column, under the "PSI Loss" heading, and across the row for the GPM.
4. Divide this number by 100 to find the PSI loss per foot.
5. Multiply this number times the length of the pipe in feet.

Sample Problem: Find the friction loss in a 42 ft. length of 3/4 in. Class 200 PVC flowing 6 GPM.

**Friction Loss Characteristics
Class 200 IPS PVC Plastic Pipe
(1120, 1220) SDR 21 C = 150 3/4" through 5"
Pressure Loss per 100**

Nominal Size	3/4"		1"		1-1/4"		1-1/2"		2"		2-1/2"	
	Velocity FPS	PSI LOSS	Velocity FPS	PSI LOSS	Velocity FPS	PSI LOSS	Velocity FPS	PSI LOSS	Velocity FPS	PSI LOSS	Velocity FPS	PSI LOSS
Flow GPM												
1	0.47	0.05	0.29	0.01	0.14	0.00	0.09	0.00	0.06	0.00	0.06	0.00
2	0.94	0.22	0.58	0.01	0.20	0.01	0.16	0.00	0.12	0.00	0.12	0.00
3	1.42	0.48	0.87	0.14	0.41	0.02	0.27	0.01	0.18	0.00	0.18	0.00
4	1.89	0.79	1.15	0.24	0.72	0.08	0.55	0.04	0.35	0.01	0.24	0.01
5	2.38	1.19	1.44	0.36	0.93	0.12	0.68	0.06	0.44	0.02	0.30	0.01
6	2.83	1.67	1.73	0.51	1.09	0.16	0.83	0.08	0.53	0.03	0.36	0.01
7	3.30	2.23	2.02	0.67	1.27	0.22	0.97	0.11	0.62	0.04	0.42	0.01
8	3.77	2.85	2.31	0.86	1.45	0.28	1.00	0.14	0.71	0.05	0.48	0.02
9	4.25	3.55	2.60	1.07	1.63	0.34	1.04	0.18	0.80	0.06	0.54	0.02
10	4.72	4.31	2.89	1.31	1.81	0.42	1.38	0.22	0.88	0.07	0.60	0.03
12	5.66	6.04	3.44	1.73	2.17	0.59	1.65	0.30	1.08	0.10	0.72	0.04
14	6.60	8.04	4.04	2.43	2.53	0.78	1.93	0.40	1.24	0.14	0.84	0.05
16	7.55	10.29	4.62	3.11	2.89	1.00	2.21	0.52	1.41	0.17	0.96	0.07
18	8.49	12.80	5.19	3.87	3.26	1.24	2.48	0.64	1.59	0.22	1.09	0.09
20	9.43	15.56	5.77	4.71	3.62	1.51	2.76	0.78	1.77	0.28	1.21	0.10
22	10.39	18.56	6.35	5.62	3.99	1.80	3.03	0.93	1.94	0.32	1.33	0.12
24	11.32	21.81	6.93	6.60	4.34	2.12	3.31	1.09	2.12	0.37	1.45	0.15
26	12.27	25.29	7.50	7.65	4.70	2.45	3.59	1.27	2.30	0.43	1.57	0.17
28	13.21	29.01	8.06	8.78	5.05	2.82	3.86	1.46	2.47	0.49	1.69	0.19
30	14.15	32.96	8.65	9.97	5.43	3.20	4.14	1.65	2.65	0.56	1.81	0.22

Friction Loss Tables, page 4

Figure 19

1. Look in the left column (FLOW G.P.M.”) on the friction loss chart and read down to the GPM in our sample.

Sample Problem:

6 GPM

2. Now, read across the top of the chart looking for the size of the pipe in our sample problem.

Sample Problem:

3/4 in .

3. Read down this column, under the “P.S.I. LOSS” heading, and across the row for the GPM.

Sample Problem:

1.67 PSI loss

4. Where the two intersect (in Step 3) is the PSI loss per 100. Divide this number by 100 to find the loss per foot.

Sample Problem:

$$\frac{1.67}{100} = 0.0167 \text{ psi loss per ft.}$$

5. Multiply your answer by the length of pipe supplying this sprinkler only (just to the next head on the zone).

Sample Problem:

0.0167 x 42 ft. = 0.701

Determining Dynamic Pressure Losses

When calculating dynamic pressures in pipes, we use the following factors:

- A) Pressure change due to elevation change.
- B) Pressure loss due to friction losses in the pipe
- C) Pressure losses in valves, meters, etc. (These losses are determined by the manufacturer and listed in product literature or technical charts.)
- D) Pressure losses due to fittings.

The following example illustrates how the dynamic pressure at a given point in a landscape irrigation system is determined. Pressure change due to the change in elevation is calculated and the friction losses are subtracted from the subtotal. The example uses the Friction Loss Charts at the back of this design manual.

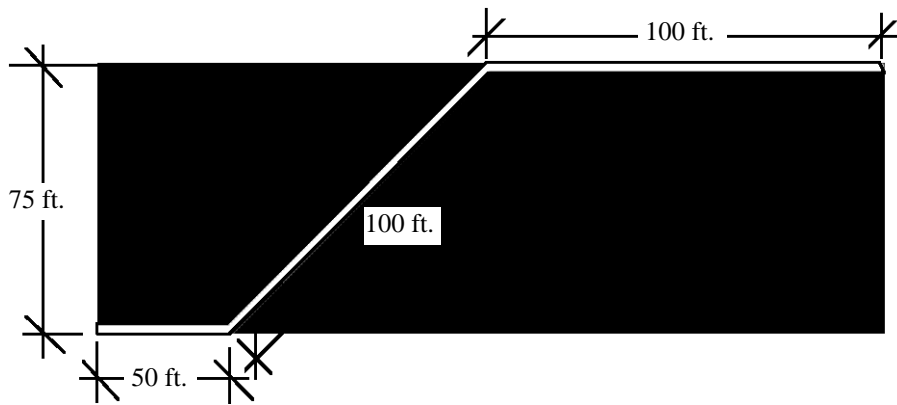

Elevation View

Figure 20

In Figure 20, all the pipe is 1-1/4-in. Class 200 PVC and the flow is 18 GPM from point A to point B. At point A, a pressure gauge reading indicates 85 PSI. In order to determine the dynamic pressure at point B, first find the pressure change due to change in elevation and then combine that with the friction loss in the pipe.

Pressure loss due to the higher elevation at point B (an elevation gain):
 $75 \text{ ft.} \times 0.433 \text{ PSI per ft. of elevation change} = 32.48 \text{ PSI less at point B}$

Pressure loss due to friction in the pipe:

Use the friction loss charts at the back of this manual to find the pressure loss at 18 GPM in 1-1/4-in. Class 200 PVC pipe: friction loss from the chart is 1.24 PSI per 100 ft.

PSI loss in pipe:

$$(50 \text{ ft.} + 100 \text{ ft.} + 100 \text{ ft.}) \times (1.24 \text{ PSI loss per } 100 \text{ ft.} \div 100 \text{ ft.}) = \text{PSI loss}$$

Note: the 1.24 PSI loss from the charts is PSI loss per 100 ft. and is divided by 100 to find the pressure loss per foot, $(1.24 \div 100 = 0.0124)$.

so, the PSI loss in pipe = $250 \text{ ft.} \times 0.0124 \text{ PSI loss per ft.}$

PSI loss in pipe = 3.10 PSI [total due to friction loss]

85.00	PSI pressure at point A
- 32.48	PSI due to elevation change
52.52	PSI subtotal at point B
- 3.10	PSI due to friction loss in pipe from point A to point B
49.42	PSI dynamic pressure at point B

Summary

There is a limited amount of pressure helping to supply water to a sprinkler system. As more sprinklers are added to a system, the GPM requirement increases. As the GPM increases, the velocity of the water increases until the pressure losses due to friction equal the pressure available at the source.

The design of a landscape irrigation system requires an understanding of water movement. Changes in elevation and friction losses in pipe, valves, and fittings affect pressure, which in turn affects sprinkler performance. Irrigation hydraulics is used to determine the volume of water available for use by the system, the pressure available at the sprinkler heads, and the correct pipe sizes.

Understanding the principles of hydraulics outlined in this section will lead to irrigation systems that have a more uniform distribution of water and cost less to install and maintain.

What You Need to Know

Water pressure is created by:

- weight of water
- pump (mechanical pressurization)

Water pressure can be measured in:

- PSI (pounds per square inch)
- ft./hd. (feet of head)

For every one foot of elevation change, the water pressure:

- Increases 0.433 PSI going downhill from the P.O.C.
- Decreases 0.433 PSI going uphill from the P.O.C.

Design Capacity

Introduction

The two questions that most frequently confuse someone learning irrigation system design are, 1) “How much water will be available for my irrigation system?” and, 2) “What pressure will I have available for my sprinklers?”

The reason there is so much confusion surrounding this topic is that there are many factors affecting how much water will be available (Design Capacity), and what the pressure will be at the sprinkler head (Dynamic, or Working Pressure); the static pressure at the source, net elevation change, the size and length of the service line and delivery line, water meter size, filters, backflow prevention devices, and the number and size of gate valves. While many texts and references refer to “restricting flows to conserve pressure”, or list “restrictions on appropriate flows”, most fail to offer an orderly, step-by-step method to answering these two basic questions.

This section will explain how to determine the flow available for use in the sprinkler system and what pressure can be expected for sprinkler operation.

Determining Water Supply and Available Pressure

How to calculate the flow or design capacity and the dynamic pressure available will vary depending upon the water source. This section is divided into three parts depending on the water source:

- I. Metered Municipal Water Sources (page 38)
- II. Unmetered Municipal Water Sources (page 51)
- III. Pump Delivered Well Sources (page 52)

Definitions

Use the diagram below along with the definitions:

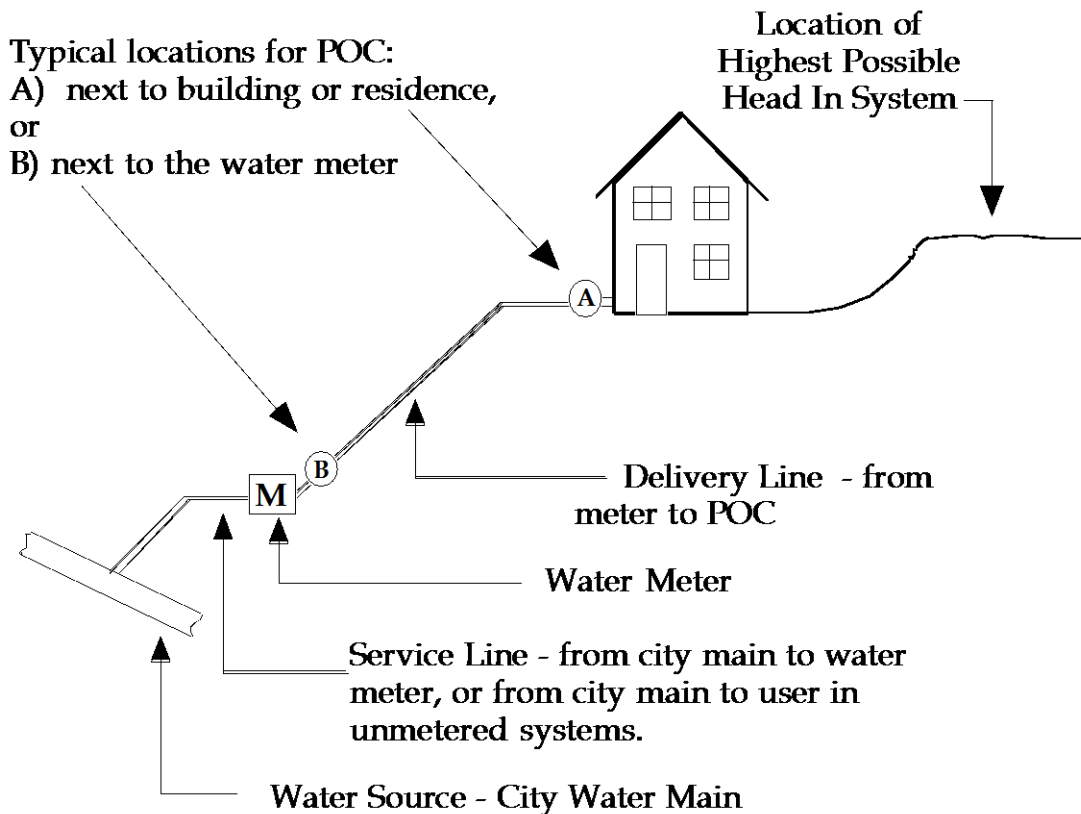

Figure 21

Curb Stop (Meter Stop) - An isolation valve installed between the service line and delivery line. In Figure 21, this would be located where the water meter is located.

Delivery Line - The pipe that connects the water meter or curb stop to the POC. It may also connect the water meter to the residence or business.

Design Capacity - The “Design Capacity” of an irrigation system is the maximum amount of water (flow) available for use at one time. This will determine how many sprinkler heads may be in operation at the same time. For example, if the Design Capacity is 18 GPM, and the sprinkler head selected for the project uses 3 GPM, only six sprinkler heads may be in operation at the same time (6 heads x 3 GPM = 18 GPM Design Capacity). If more than six of these sprinklers are needed to cover the area being irrigated, additional control valves must be installed so a maximum of six heads are used at one time.

Dynamic Pressure - The available dynamic pressure, also known as working pressure, is simply the water pressure calculated while the water is flowing.

The “Dynamic Pressure at Design Capacity” is a calculation of the pressure (PSI) available at the maximum system flow rate. This pressure is calculated at the system Point of Connection (POC). The dynamic pressure at the POC will influence your choice of sprinkler heads. For example, you would not choose a head with an operating pressure rating that is above the available dynamic pressure

Estimated Dynamic Pressure at Worst Case Head - Once the Dynamic Pressure at Design Capacity is calculated, an estimate is made of the pressure that will be available for the sprinklers. The “Worst Case Head” indicates this head is the highest head in the system. The Design Capacity (GPM) and Estimated Dynamic Pressure at Design Capacity (PSI) are used to select the sprinklers. Pressure and flow limitations are two of the prime factors in sprinkler selection.

Flow - The volume/velocity rate water moving through a system. This can be measured in gallons per minute (GPM), gallons per hour (gph), liters per second (l/s), liters per minute (l/min), or cubic meters per hour (m³/hr).

Point of Connection - The Point of Connection (POC) is where the irrigation system is connected to the water source. This represents a logical or convenient location to connect the irrigation system to the water supply.

Service Line - The service line is the pipe connection between the city main in the street and the water meter. In the case of unmetered systems, it is the pipe between the city water main and the curb stop.

Water Meter - A device used to measure water usage. In southern climates, the meter is usually located near the property line, close to the city main line. In northern climates, the meter is usually in a basement or other indoor location.

Working Pressure - See Dynamic Pressure

Hunter[®]

Calculating Dynamic Pressure at Design Capacity

The following sections explain how to determine design capacity and dynamic pressure at design capacity, and estimate the dynamic pressure for the worst case head for the three most common landscape irrigation water sources. The three most common water sources are: 1) metered municipal systems, 2) unmetered municipal systems, and 3) pumping from a well.

I. Metered Municipal Systems

These instructions and the worksheet refer to the sample problem in Figure 22. The worksheet on page 39 has been included for your convenience. Using the sample problem in Figure 22, complete the worksheet as you read this section.

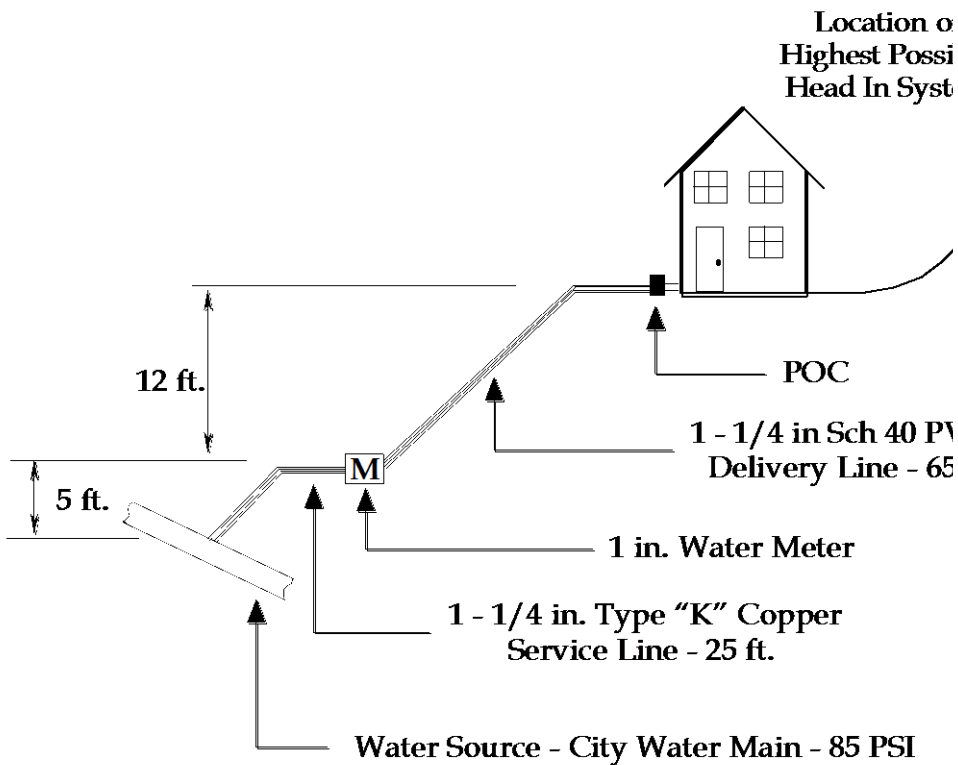

Figure 22

(METERED SYSTEMS)
**Design Capacity and Working Pressure
 Worksheet**

CALCULATING DESIGN CAPACITY AND DYNAMIC PRESSURE

A. Record Site Information

1	Static* Pressure at the Source (Main)		_____	PSI
2	Net elevation Change (Source to POC) ± uphill, - downhill)		_____	FEET (+
3	Pressure change due to elevation: Line 2 x 0.433 =		_____	PSI
4	Static Pressure at POC: Line 1 +/- Line 3 =		_____	PSI
		<i>Number/Length</i>	<i>Size</i>	<i>Type</i>
5	Service Line	_____	_____	_____
6	Delivery Line	_____	_____	_____
7	Water Meter	_____	_____	_____
8	Isolation Valves	_____	_____	_____
9	Other	_____	_____	_____

B. Determine Design Capacity

	<i>Factor</i>	<i>Restriction</i>	<i>GPM With Restriction</i>
10	Pressure loss through the water meter.	Not to exceed 10% of available PSI at the source(Line 1)	_____ GPM
11	Volume through the water meter.	Not to exceed 75% of maximum safe flow of the meter.	_____ GPM
12	Velocity through the service line.	Velocity not to exceed 7.5 fps (Main to meter)	_____ GPM
13	Design Capacity Lowest GPM of the three flows rates - lines 10, 11, and 12.		
		_____	GPM

C. Calculate Dynamic Pressure at Design Capacity

Pressure Losses from Source(City Water Main) to the POC

14	Pressure loss in the Service Line	_____ PSI loss (per 100') x _____ ft./100 = _____ PSI
15	Pressure loss in the Delivery Line	_____ PSI loss (per 100') x _____ ft./100 = _____ PSI
16	Pressure loss in the Water Meter at design capacity	= _____ PSI
17	Pressure loss in the Gate Valves:	_____ Equivalence Factor
		x _____ PSI loss per 100' of Standard Steel/100
		x _____ Number of Gate Valves = _____ PSI
18	Other pressure losses _____	= _____ PSI
19	Pressure loss from the source to POC (add Lines 14 through 18)	_____ PSI
20	Approximate Dynamic Pressure at Design Capacity	
	Static Pressure at the POC (Line 4 above)	_____ PSI
	Subtract the PSI lost from the source to the POC (Line 19)	_____ PSI
	Approximate Dynamic Pressure at Design Capacity	_____ PSI



D. Estimate Pressure Available at “Worst-Case” Head

21 Pressure change due to elevation change from the POC to the highest head in the system. _____ ft. x 0.433 = _____ PSI

22 Pressure subtotal (subtract Line 21 from Line 20; for worst case heads which are lower than the POC, add Lines 20 and 21) _____ PSI

23 Estimated Pressure Available at worst case-head two-thirds of subtotal: Line 22 _____ PSI x 0.67 = _____ PSI

Pressure Available for Sprinkler Selection and Operation _____ PSI

*Although this is referred to as static pressure, in municipal systems it is taken to mean the minimum dynamic pressure at the water main.



A. Record Site Information

Line #1 - Static* Pressure at the Source: For municipal systems, the static pressure at the source can be obtained from the water purveyor. This is usually a municipal water utilities department, quasi-governmental agency, or a private water company. It is suggested that this information be obtained from the water company rather than by using a gauge because the water company can also tell you what minimum pressure you would expect in the main line. Service line size and type can be obtained at the same time, or you can use a string to wrap around the pipe and compare that length to the chart on page 11 in the Hunter Friction Loss Tables. The water meter size is stamped on the meter.

Sample Problem: Minimum static pressure in the city main = 85 PSI

* In a municipal system the water in the city main would seldom, if ever, be at a static state. However, since the pressure in the city main would unlikely change because of the irrigation system demand, the pressure in the main is considered to be static.

Line #2 - Net Elevation Change: The net elevation change is determined by estimating the difference in elevation from the point where the static water pressure is taken (line #1) to the POC. More accurate estimates may be made if civil engineering plans are available.

Sample Problem: Elevation gain $5' + 12' = 17'$

Line #3 - Pressure Change Due to Elevation: This is calculated by multiplying the elevation change from the source to the POC (line #2) by 0.433 PSI (PSI change per foot of elevation change).

Sample Problem: $17' \times 0.433 \text{ PSI per ft.} = 7.36 \text{ PSI}$

Line #4 - Static Pressure at POC: For most systems the POC is higher in elevation (uphill) in relation to the water main or source. In these cases the pressure change (line #3) is subtracted from the pressure at the source. If the POC is lower in elevation (downhill), the change in pressure would be added to the pressure at the source (line #1).

Sample Problem:

85 PSI at the city main - 7.36 PSI (POC is uphill from main) = 77.64 PSI

Line #5 - Service Line: This is the line in a municipal system that runs from the city main in the street to the water meter. Data on size and type should be obtained when contacting the water purveyor about static pressure (line #1).

Sample Problem: 1-1/4 in. Type “K” Copper, 25 ft.

Line #6 - Delivery Line: The delivery line is installed by the contractor that built the house or commercial project. It is not information the water purveyor will be able to provide. The information can be obtained from project plans or on-site investigation. (Note: If the POC is at the water meter there will not be a delivery line and this portion can be ignored.)

Sample Problem: 1-1/4 in. Sch. 40 PVC - 65 ft

Line #7 - Water Meter: This is installed by, or under the direction of, the water purveyor. Data on size and type can be obtained when inquiring about static pressure (line #1). In some cases, size can be determined during a site inspection.

Sample Problem: 1 inch water meter

Line #8 - Isolation Valves: These are often used to isolate portions of the system. They may be a gate valve, ball valve, or globe type valve. There are none used in this example.

Note: the meter stop will not be considered in this example because the pressure losses are considered to be minor.

Line #9 - Other: This line would be for other system components which could cause a pressure loss in the system – such as a water filter, pressure regulator, or a backflow prevention device. Manufacturers publish pressure loss (also known as friction loss) information in their product catalogs. There are no other components for this example.

B. Determine Design Capacity

The Design Capacity is the maximum flow rate available for system operation. There are three factors that restrict the available flow (GPM) in a landscape irrigation system:

- 1) *Pressure loss* through the water meter - because pressure is limited to that available at the main, no more than 10% of that pressure should be expended through the meter.
- 2) *Volume* through the water meter - because a safety margin for possible changes in the system or for other uses on the project should be included in the design, no more than 75% of the maximum safe capacity of the meter should be used for irrigation.
- 3) *Velocity* through the service line - because excessive water velocity can result in excessive pressure losses and potential system failure, velocity through the service line should be limited to 7.5 feet per second (fps).

Lines 10 -12 will determine a maximum flow under each restrictive factor. The Design Capacity is the lowest of these three flow rates.

Line #10 - Pressure Loss Through the Meter: Limited to 10% of Static Pressure at the Source:

Sample problem: 1 inch meter

- A) Determine 10% of the pressure at the main by multiplying 10% (0.10) times the PSI at the main, line #1 (85 PSI).

$$85.0 \times 0.10 = 8.5 \text{ PSI allowable loss through the water meter}$$

- B) Turn to page 11 for the chart “Pressure Loss Through Water Meters” in the Hunter Friction Loss Tables at the end of this design manual.
- C) Select the column for 1 inch water meters.
- D) Read down the column until pressure loss is as close to the allowable loss (8.5 PSI) without exceeding it.
- E) Read across to left hand column to determine the volume at that point (36 GPM).
- F) Record 36 GPM on line #10 of the worksheet.

Line #11 - Volume Through the Meter: Limited to 75% of Water Meter Capacity

Sample problem: 1 inch water meter

- A) Turn to page 11 for the chart “Pressure Loss Through Water Meters” in the Hunter Friction Loss Tables at the end of this design manual.
- B) Locate the column for size of water meter (1 inch).
- C) Read down the pressure loss column under 1 inch meters until pressure loss figures stop.
- D) Read across to left hand column to determine the volume at that point (50 GPM). This represents the maximum safe flow for that size meter.
- E) Determine 75% of maximum safe flow by multiplying the flow by 75% (0.75).
$$50 \text{ GPM} \times 0.75 = 37.5 \text{ GPM}$$
- F) Record 37.5 GPM on line #11 of the worksheet.

Line #12 - Velocity in the Service Line: This is the friction loss due to the speed at which water flows through the service line. Because excessive water velocity can result in excessive pressure losses and potential system failure, velocity through the service line is limited to 7.5 Feet Per Second (fps)*.

Sample Problem: 1-1/4 inch Type “K” Copper

- A) Turn to the chart for the type of service line used, page 9 in the Hunter Friction Loss Tables at the end of this design manual.
- B) Locate the column for the size of service line (1-1/4 inch).
- C) Read down the column for velocity (fps) until the velocity reaches 7.5 fps (or as high a velocity as listed without exceeding 7.5 fps).
- D) Read across from that point to the left hand column to determine volume (GPM) at allowed 7.5 fps (28 GPM).
- E) Record 28 GPM on line #12 of the worksheet.

Note: This 7-1/2 fps restriction is sometimes disregarded in the industry because service line is usually copper and is unlikely to be damaged by water hammer. If you disregard this restriction, a check of actual pressure loss through the service line must be made to insure the pressure loss incurred due to high velocity is not excessive. Conversely, some areas will not allow a velocity as high as 7-1/2 fps -- check the local restrictions.

Line #13 - Design Capacity: Lowest of the three flow rates listed on Lines 10 - 12. The lowest flow rate is selected because this flow rate is the only one that will not exceed any of the three restrictions on Design Capacity: Pressure Loss Through the Meter, Volume Through the Meter, and Velocity Through the Service Line. List the lowest of the three flow rates on line #13.

Sample Problem: 28 GPM

Hunter®

C. Calculate Dynamic Pressure at Design Capacity

Now that a flow rate (Design Capacity) has been established, this flow rate can be used to estimate the dynamic pressure at the Point of Connection. Pressure losses from the source to the POC include those through the service line, delivery line, water meter, isolation valves, or other system components. Note: not all components listed are present in all systems.

Line #14 - Pressure Loss in the Service Line: Determine the pressure loss in the service line.

Sample Problem: 1-1/4 inch Type “K” Copper

A) Turn to the chart for the type of service line used, page 9 in the Hunter Friction Loss Tables at the end of this design manual.

B) Read down the left hand column (Flow GPM) to the design capacity, line #13.

Sample Problem: 28 GPM

C) Read across to the right from that point to the column for PSI loss in 1-1/4” “K” copper.

Sample Problem: 7.97 PSI per 100 ft.

D) Record this in the first space on line #14.

Sample Problem: 7.97

E) Record the length of the service line in the second space on line #14, this information was recorded on line #5 of the worksheet.

Sample Problem: 25 ft.

F) Determine the pressure loss through the service line by multiplying the pressure loss per 100 ft. times the length of the service line and dividing the answer by 100 to find the actual PSI loss in the service line.

Sample Problem:

$$\frac{(7.97 \times 25)}{100} = 1.99 \text{ PSI loss in the service line}$$

G) Record this PSI loss on line #14 of the worksheet.

Sample Problem: 1.99

Line #15 - Pressure Loss in the Delivery Line: Determine the pressure loss in the delivery line.

Sample Problem: Schedule 40 PVC

A) Turn to the chart for the type of delivery line used, page 2 in the Hunter Friction Loss Tables at the end of this design manual.

B) Read down the left hand column (Flow GPM) to the design capacity, line #13.

Sample Problem: 28 GPM

C) Read across to the right from that point to the column for PSI loss in 1-1/4" Schedule 40 PVC.

Sample Problem: 4.25 PSI per 100 ft.

D) Record this in the first space on line #15.

Sample Problem: 4.25

E) Record the length of the delivery line in the second space on line #15. This information was recorded on line #6 of the worksheet.

Sample Problem: 65

F) Determine the pressure loss through the delivery line by multiplying the pressure loss per 100 ft. times the length of the delivery line and dividing the answer by 100 to find the actual PSI loss in the delivery line.

Sample Problem:

$$\frac{(4.25 \times 65)}{100} = 2.76 \text{ PSI loss in the service line}$$

G) Record this PSI loss on line #15 of the worksheet.

Sample Problem: 2.76

Line #16 - Pressure Loss in the Water Meter: Determine the pressure loss in the water meter.

A) Turn to page 11 for the chart “Pressure Loss Through Water Meters” in the Hunter Friction Loss Tables at the end of this design manual.

B) Read down the left hand column (Flow GPM) to the design capacity, line #13.

Sample Problem: 28 GPM

C) Read across to the right from that point to the column for pressure loss in 1 inch water meters.

Sample Problem: 4.60 PSI loss

D) Record this PSI loss on line #16 of the worksheet.

Sample Problem: 4.60

Line #17 - Pressure Loss in the Isolation Valves: Isolation valves may be gate valves, ball valves, globe valves, meter cocks or curb stops. While there will be a meter cock or curb stop in most municipal systems, the pressure losses incurred are generally considered minimal. If they are included, pressure losses can be estimated by use of the equivalent length chart, “Pressure Loss in Valves and Fittings,” on page 10 in the Hunter Friction Loss Tables at the end of this design manual. There are no isolation valves included in this example.

Line #18 - Other Pressure Losses: These may include pressure losses through backflow prevention devices, filters or other system components located between the water source and the POC. Manufacturers publish pressure loss (also known as friction loss) information in their product catalogs. There are no other components for this example.

Line #19 - Pressure Loss from the Source to POC: Add the pressure losses recorded on lines 14 - 18.

Sample Problem: $1.99 + 2.76 + 4.60 + 0.0 + 0.0 = 9.35$ PSI

Line #20 - Approximate Dynamic Pressure at Design Capacity:

- 1) Record the static pressure previously determined on line #4.
- 2) Record the pressure loss subtotal from line #19.
- 3) Subtract these two lines to determine the approximate dynamic pressure expected at the POC at the maximum system flow rate (Design Capacity).

Sample Problem:

static pressure from line #4	77.64 PSI
pressure loss subtotal from line #19	<u>- 9.35 PSI</u>
approximate Dynamic Pressure at the POC	68.29 PSI

D. Estimate Pressure Available at "Worst Case" Head

At this point the Design Capacity (GPM from line #13) and Dynamic Pressure at the POC (PSI from line #20) have been calculated. The Design Capacity establishes the maximum flow rate for the system and the Dynamic Pressure at the POC provides us with a basis for estimating the dynamic pressure that will be available to operate the sprinklers.

In order to begin our irrigation system design, an estimate of the available dynamic pressure at the worst case head must be made. This is calculated by:

- 1) Adding or subtracting the pressure change due to the change in elevation between the POC and the highest head in the system.
- 2) Estimating the amount of pressure that would remain after normal pressure losses between the POC and the highest head; typically 1/3 of the available dynamic pressure is lost and 2/3 remains available for sprinkler operation.

Line #21 - Pressure Change Due to Elevation Change:

Calculate the pressure change due to elevation between the POC and the highest head.

Sample Problem: the highest head is 10 ft. above the POC. 10 x
0.433 = 4.33 PSI

Line #22 - Estimated Pressure Subtotal: If the highest head in the system is above the POC, subtract the pressure change calculated on line #21 from line #20, if the highest head is lower than the POC, the pressure change from line #21 must be added to the pressure on line #20.

Sample Problem: 68.29 - 4.33 = 63.96 PSI

Line #23 - Two Thirds Estimate: A normal landscape irrigation system will lose approximately one third (1/3) of the dynamic pressure available between the POC and the highest head. These losses occur because of friction loss in pipe, pressure loss in valves and fittings, and pressure loss through backflow prevention devices or other system components. Because of these losses, only two thirds of the dynamic pressure available at the POC is available for sprinkler operation. In this step, multiply the pressure subtotal calculated on line #22 by 2/3 (0.67).

Sample Problem: 63.96 x 0.67 = 42.85 PSI

How To Use The Worksheet Information

With this worksheet you have determined the following:

- **Design Capacity (line #13):** The Design Capacity is the maximum safe flow available for use in the sprinkler system. This flow will determine how many heads can be operated at any one time. For example, if the design capacity is 18 GPM, the system can have six 3 GPM heads operating at one time (6 heads x 3 GPM = 18 GPM). If more than 6 heads are needed for the project, additional valves must be added so that no more than 18 GPM would be used at one time.

- **Dynamic Pressure at Design Capacity (line #20):** This is the dynamic pressure that can be expected at the POC when the system is using the maximum safe flow (Design Capacity, line #13). This figure is used 1) as a starting point in estimating the pressure that will be available at the worst case head, and 2) as a guideline when the irrigation design is completed to check total system pressure required and assure the system is designed correctly.

- **Estimated Pressure Available for Sprinkler Operation (line #23):** This is an estimate of the dynamic pressure available for sprinkler operation at the highest head in the system. If there is a significant drop in elevation to the location of other heads in the system, the pressure gain due to the drop in elevation could be added to this figure. This pressure should be used as a guide for selecting sprinklers. For example, if the pressure on line #23 is 40 PSI, then sprinklers selected for the project should have operating pressures of 40 PSI or less.

After the preliminary design has been completed, a thorough calculation of the friction loss in the system should be made before committing to the final irrigation plan. This calculation should include friction loss in the lateral lines and all other components back to the point of connection, and should be based on the GPM actually expected to be used by the sprinkler heads chosen. This subject is covered later under “Friction Losses”.

Design Problem

Many times, you will use a pressure gauge attached to an outside faucet to measure the static pressure. When measuring the PSI in this manner, be sure that no water is running anywhere on the property. Be aware that the static pressure can vary throughout the day; it's best to take the pressure measurement at the same time of day as you plan on watering.

Remember: the static pressure at the POC will be greater if the measurement is taken at a point above the POC, and lower at the POC if the measurement is taken at a point below the POC.

Using the following design and the information below, complete a *Design Capacity and Working Pressure* worksheet :

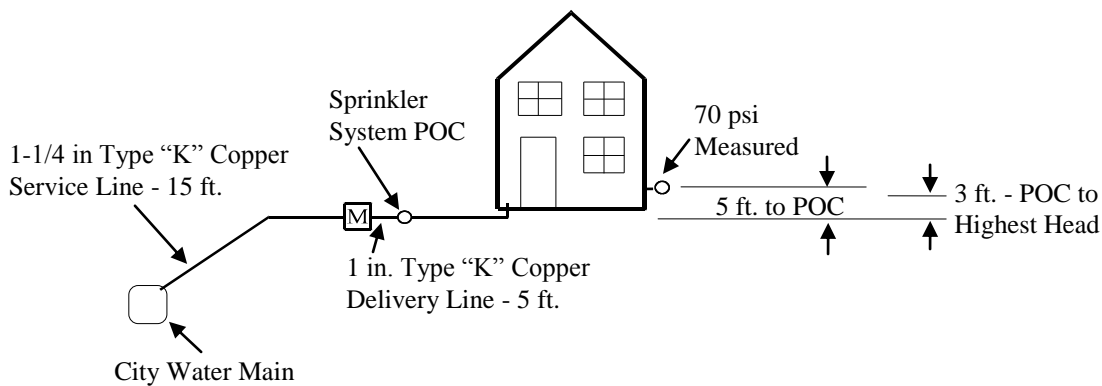

Static Pressure at P.O.C.				72 PSI
Net elevation change - P.O.C. to highest head				+3 ft.
Service Line	15 ft.	1-1/4"	Type K Copper	
Delivery Line	5 ft.	1"	Type K Copper	
Water Meter size		5/8"		

Static Pressure at POC is measured as follows:

1. Static pressure measured at the hose bib is 70 psi.
2. Elevation change from the hose bib to the POC is 5 feet (POC is lower).
3. $5 \text{ ft} \times .433 \text{ psi/ft} = 2.165 \text{ psi}$
4. $70 \text{ psi} + 2.165 \text{ psi} = 72.165 \text{ psi}$ at the POC

II. Unmetered Municipal Systems

Calculation of design capacity and dynamic pressure at design capacity in unmetered systems differs from metered systems in that the restrictions are based only on service line velocity.

When filling out the worksheet to determine design capacity and working pressure in an unmetered system, simply disregard any questions relating to water meters.

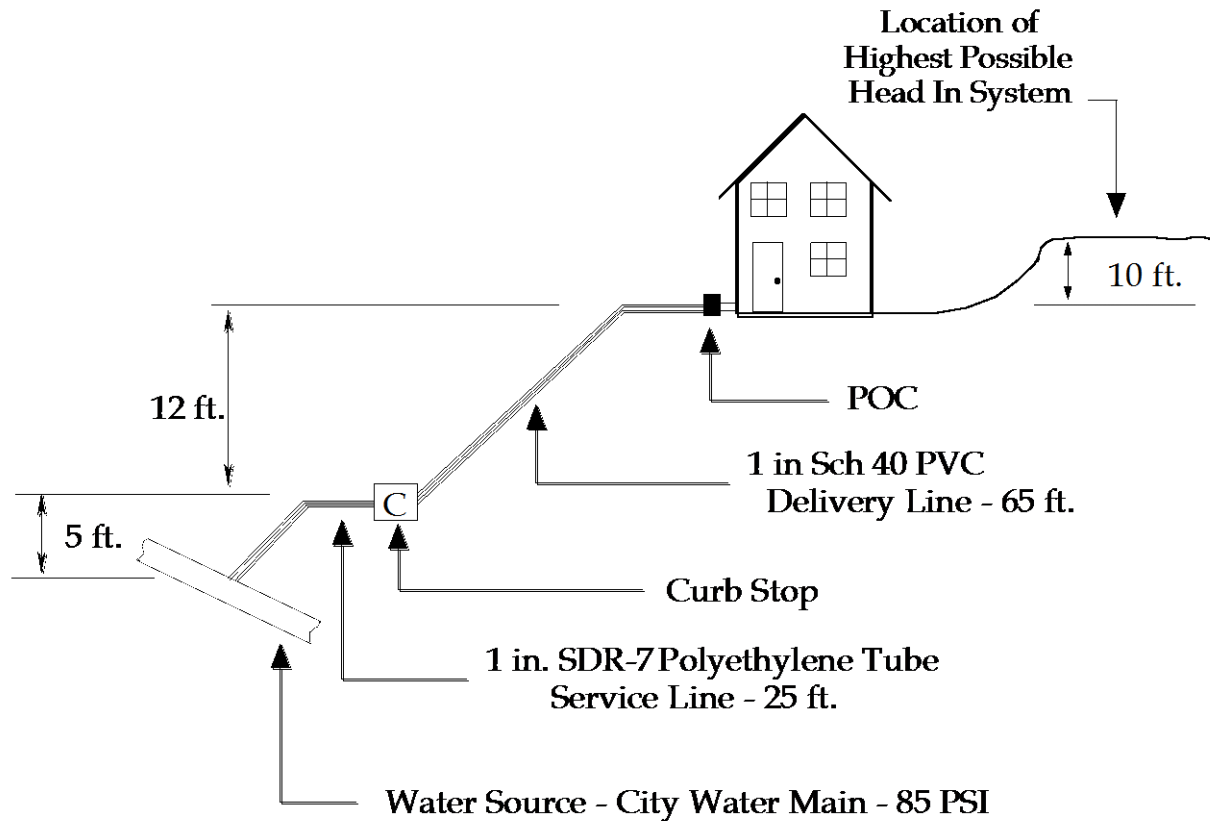
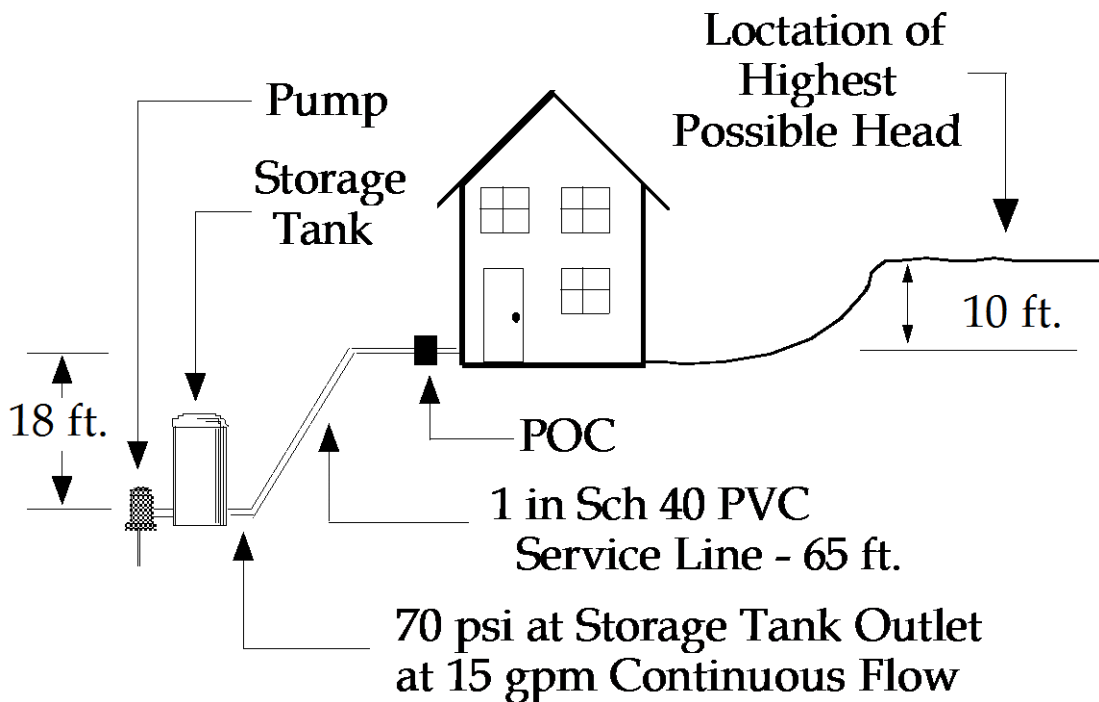

Figure 23

III. Systems Supplied by a Pump

Calculation of design capacity and dynamic pressure at design capacity on systems with a pump as the water source must begin with an evaluation of the capacity of the well and pump. The process of quantifying flow rates and pressures in pump systems can be difficult. Flow rates, well draw-down and the subsequent pressure delivered by the pump can vary by season and by the year. Contact a well/pump expert for assistance with the best method for determining well/pump capacity in your area.

These instructions and worksheet refer to the sample problem in figure 24. The worksheet on page 53 has been completed using the sample problem in Figure 24. Follow along on the worksheet as you read this section.



Pump capacity: 15 GPM at 70 PSI
Elevation from pump discharge to POC: 18 ft.
Delivery line: 1 in. Sch 40 - 65 ft.

Figure 24

Design Capacity and Working Pressure Worksheet

CALCULATING DESIGN CAPACITY AND DYNAMIC PRESSURE

A. Record Site Information

1 Dynamic pressure at the discharge point	<u>70</u>		PSI
2 Pump available flow at discharge point	<u>15</u>		GPM
3 Net elevation change (discharge to POC) ± uphill, - downhill)	<u>+ 18</u>		FEET (+
4 Pressure change due to elevation: Line 3 x 0.433 =	<u>- 7.79</u>		PSI
5 Pressure at POC: Line 1 +/- Line 4 =	<u>62.21</u>		PSI
6 Delivery Line	<u>Number/Length</u> 65 ft.	<u>Size</u> 1 in.	<u>Type</u> Sch 40 PVC
7 Isolation Valves	<u>--</u>	<u>--</u>	<u>--</u>
8 Other	<u>--</u>	<u>--</u>	<u>--</u>

B. Determine Design Capacity

	<u>Factor</u>	<u>Restriction</u>	<u>GPM With Restriction</u>
9 Pump/Well GPM capacity		Continuous supply available at discharge point (Line 2)	<u>15.0</u> GPM
10 Pump Safety Factor		Not to exceed 90% of continuous supply available at discharge point <u>15.0</u> x 0.10	
=	<u>1.5</u>		GPM
11 Design Capacity (subtract Line 10 from Line 9)			<u><u>13.5</u></u> GPM

C. Calculate Dynamic Pressure at Design Capacity

Pressure Losses from Discharge Point to the POC

12 Pressure reduction 10% as Pump Safety Factor	<u>70</u>	x 0.10 =	<u>7.0</u> PSI
13 Pressure loss in the Delivery Line	<u>4.19</u> PSI loss (per 100')	<u>65</u> ft./100 =	<u>2.72</u> PSI
14 Pressure loss in the Isolation Valves:	_____ Equivalence factor		
	x _____ PSI loss per 100' of standard steel/100		
	x _____ Number of valves	=	<u>--</u> PSI
15 Other pressure losses _____		=	<u>--</u> PSI
16 Pressure loss from the discharge point to POC (add Lines 12 through 15)			<u>9.72</u> PSI
17 Approximate Dynamic Pressure at Design Capacity			
Dynamic pressure at the POC (Line 5 above)	<u>62.21</u>		PSI
Subtract the PSI lost from the discharge point to the POC (Line 16)	<u>9.72</u>		PSI
Approximate Dynamic Pressure at Design Capacity	<u>52.99</u>		PSI

D. Estimate Pressure Available at “Worst-Case” Head

18	Pressure change due to elevation change from the POC to the highest head in the system. <u>10</u> ft. x 0.433 =	<u>4.33</u> PSI
19	Pressure subtotal (subtract Line 18 from Line 17; for worst case heads which are lower than the POC, add Lines 17 and 18)	<u>48.66</u> PSI
20	Estimated Pressure Available at worst case-head two-thirds of subtotal: Line 19 <u>48.66</u> PSI x 0.67 =	<u>32.60</u> PSI
	Pressure Available for Sprinkler Selection and Operation	<u>32.60</u> PSI

A. Record Site Information

Line #1 - Dynamic Pressure at the Discharge Point: The pressure and the design capacity of pump/well systems differ from municipal systems in that they are dependent on the capacity of individual pumps and wells. These flow rates and pressures vary widely even between wells located close to one another. Well/pump systems differ in the determination of design capacity because of the need to establish the capacity of the well or pump. This flow can vary from just a few gallons per minute to hundreds of gallons per minute. The pump/well capacity and the pump's discharge pressure may be obtained from:

- 1) The property owner - if they have records from past pump/well tests.
- 2) The company installing the pump.
- 3) An on-site test conducted by a pump engineer or well drilling firm.

Sample Problem: Dynamic pressure at the discharge point = 70 PSI

Line #2 - Available Flow at the Discharge Point: This is obtainable from the above sources. (With pump systems, available flow is generally stated as "___ GPM at ___ PSI".)

Sample Problem: 15 GPM

Line #3 - Net Elevation Change: The net elevation change is determined by estimating the difference in elevation from the discharge point of the pump or well (point used on line #1) to the sprinkler system POC.

Sample Problem: Elevation gain = 18'

Line #4 - Pressure Change Due to Elevation: This is calculated by multiplying the elevation change from the discharge point to the POC (line #3) by 0.433 PSI (PSI change per foot of elevation change).

Sample Problem: 18' x 0.433 PSI per ft. = 7.79 PSI

Line #5 - Pressure at POC: If the POC is higher in elevation (uphill) in relation to the discharge point, the pressure change (line #4) is subtracted from the pressure at the source (line #1). If the POC is lower in elevation (downhill), the change in pressure would be added to the pressure at the source.

Sample Problem: 70 PSI (at the discharge point)
- 7.79 PSI (POC is uphill from main)
= 62.21 PSI

Line #6 - Delivery Line: This is the line that runs from the discharge point to the POC. Data on size and type are gathered when determining pump/well capacity.

Sample Problem: 65 ft. of 1 in. Schedule 40 PVC

Line #7 - Isolation Valves: These are often used to isolate portions of the system. They may be a gate valve, ball valve, or globe type valve. There are none used in this example.

Line #8 - Other: This line would be for other system components which could cause a pressure loss in the system such as a water filter, pressure regulator, or a backflow prevention device. There are none for this example.

B. Determine Design Capacity

The Design Capacity is the maximum flow rate at the discharge point which is available for system operation. The Design Capacity is limited by the capacity of the well and pump. Additionally, pump systems should be designed at no more than 90% of system capacity to reduce the chance of pump cavitation. Pump cavitation is caused when the entrance pressure is reduced to a point where air pockets form in the pump. The result is inefficient pump operation, and the pump may prematurely wear out and fail.

Line #9 - Pump/Well GPM Capacity: The pump/well GPM capacity is determined by testing, or is obtained from the pump installation company, as described above. Record the pump's available flow at discharge point (from line 2).

Sample Problem: 15 GPM

Line #10 - Pump Safety Factor: In order to reduce the chance of pump cavitation, the design capacity should not exceed 90% of the continuous supply available at the discharge point. Here, the pump/well GPM capacity is multiplied by 10% (0.10).

Sample Problem:

A) Record the pump/well GPM capacity (Line #9) in the first space on Line #10.

B) Multiply the pump/well GPM capacity by 0.10. 15 x
 $0.10 = 1.5$ GPM capacity safety factor

Line #11 - Design Capacity: The Design Capacity is the maximum flow rate at the discharge point that is available for system operation. This is determined by subtracting line #10 from line #9.

Sample Problem: $15.0 \text{ GPM} - 1.5 \text{ GPM} = 13.5 \text{ GPM}$

C. Calculate Dynamic Pressure at Design Capacity

Now that a flow rate (Design Capacity) has been established, this flow rate can be used to estimate the dynamic pressure at the POC. Pressure losses from the source to the POC include those through the delivery line, isolation valves, or other system components.

Note: not all components listed are present in all systems.

Line #12 - Pressure Reduction - 10% as Pump Safety

Factor: To further reduce the chance of pump cavitation, the discharge pressure should not exceed 90% of the pump's available pressure at the discharge point. Here, the stated pressure is multiplied by 10% (0.10).

Sample Problem:

A) Record the dynamic pressure at the discharge point (line #1) in the first space on line #12.

B) Multiply the dynamic pressure at the discharge point by 0.10.

Sample Problem: $70 \times 0.10 = 7$ PSI pressure safety factor

Line #13 - Pressure Loss in the Delivery Line: Determine the pressure loss in the delivery line.

Sample Problem: 1 inch Schedule 40 PVC

A) Turn to the friction loss chart for the type of delivery line used, page 2 in the Hunter Friction Loss Tables at the end of this design manual.

B) Read down the left hand column (Flow GPM) to the design capacity, line 11.

Sample Problem: 13.5 GPM

C) Read across to the right from that point to the column for PSI loss in 1" Schedule 40 PVC.

Sample Problem: Note that there is not a listing for 13.5 GPM. Here, you can simply round down to 13 GPM, or you can figure the partial GPM as follows:

1) PSI loss for 14 GPM = 4.47 PSI per 100 ft.
subtract the PSI loss for 13 GPM = 3.90 PSI per 100 ft.
0.57 PSI per 100 ft.

2) **multiply** .57 PSI per 100 ft. x .5 GPM = 0.285
PSI loss for .5 GPM per 100 ft.

3) **add** 0.285 GPM loss for .5 GPM
3.9 GPM loss for 13 GPM
4.185 GPM loss for 13.5 GPM

Answer to Sample Problem: 4.19 PSI loss per 100 ft.

D) Record this in the first space on line #13.

Sample Problem: 4.19

E) Record the length of the delivery line in the second space on line #13. This information was recorded on line #6 of the worksheet.

Sample Problem: 65 ft

F) Determine the pressure loss through the delivery line by multiplying the pressure loss per 100 ft. times the length of the delivery line and dividing the answer by 100 to find the actual PSI loss in the delivery line.

Sample Problem:

$$\frac{(4.19 \times 65)}{100} = 2.72 \text{ PSI loss in the delivery line}$$

G) Record this PSI loss on line #13 of the worksheet.

Sample Problem: 2.72

Line #14 - Pressure Loss in the Isolation Valves: Isolation valves may be gate valves, ball valves, or globe valves. While there will be a meter cock or curb stop in most municipal systems, the pressure losses incurred are generally considered minimal. If they are included, pressure losses can be estimated by use of the equivalent length chart, “Pressure Loss in Valves and Fittings,” on page 10 in the Hunter Friction Loss Tables at the end of this design manual. There are no isolation valves in this example.

Line #15 - Other Pressure Losses: These may include pressure losses through backflow prevention devices, filters, or other system components located between the water source and the POC. There are none in this example.

Line #16 - Pressure Loss from the Source to POC: Add the pressure losses recorded on lines 12 - 15.

Sample Problem: $7.0 + 2.72 + 0.0 + 0.0 = 9.72$ PSI

Line #17 - Approximate Dynamic Pressure at Design Capacity:

- 1) Record the pressure previously determined on line #5.
- 2) Record the pressure loss subtotal from line #16.
- 3) Subtract these two lines to determine the approximate dynamic pressure expected at the POC at the maximum system flow rate (Design Capacity).

Sample Problem:

pressure from line #5	62.21 PSI
pressure loss subtotal from line #16	<u>- 9.72 PSI</u>
approximate Dynamic Pressure at the POC	52.99 PSI

D. Estimate Pressure Available at "Worst Case" Head

At this point the Design Capacity (GPM from line #11) and Dynamic Pressure at the POC have been calculated. The Design Capacity establishes the maximum flow rate for the system and the Dynamic Pressure at the POC provides us with a basis for estimating the dynamic pressure that will be available to operate the sprinklers.

In order to begin our irrigation system design an estimate of the available dynamic pressure at the worst case head must be made. This is calculated by:

- 1) Adding or subtracting the pressure change due to the change in elevation between the POC and the highest head in the system.
- 2) Estimating the amount of pressure that would remain after normal pressure losses between the POC and the highest head; typically 1/3 of the available dynamic pressure is lost and 2/3 remains available for sprinkler operation

Line #18 - Pressure Change Due to Elevation Change:

Calculate the pressure change due to elevation between the POC and the highest head.

Sample Problem: the highest head is 10 ft. above the POC.

$$10 \times 0.433 = 4.33 \text{ PSI}$$

Line #19 - Estimated Pressure Available for Sprinkler

Operation: If the highest head in the system is above the POC, subtract the pressure change calculated on line #18 from line #17, if the highest head is lower than the POC, the pressure change from line #18 must be added to the pressure on line #17.

Sample Problem: $52.99 - 4.33 = 48.66 \text{ PSI}$

Line #20 - Two Thirds Estimate: A normal landscape irrigation system will lose approximately one third (1/3) of the dynamic pressure available between the POC and the highest head. These losses occur because of friction loss in pipe, pressure loss in valves and fittings, and pressure loss through check valves or other system components. Because of these losses, only two thirds of the dynamic pressure available at the POC is available for sprinkler operation. In this step, multiply the pressure subtotal calculated on line #19 by 2/3 (0.67).

Sample Problem: $48.66 \times 0.67 = 32.60 \text{ PSI}$

How To Use The Worksheet Information

With this worksheet you have determined the following:

- **Design Capacity (line #11):** The Design Capacity is the maximum safe flow available for use in the sprinkler system. This flow will determine how many heads can be operated at one time. For example, if the design capacity is 18 GPM, the system can have six 3 GPM heads operating at one time (6 heads x 3 GPM = 18 GPM). If more than 6 heads are needed for the project, additional valves must be added so that no more than 18 GPM would be used at one time.
- **Dynamic Pressure at Design Capacity (line #17):** This is the dynamic pressure that can be expected at the POC when the system is using the maximum safe flow (Design Capacity, line #11). This figure is used 1) as a starting point in estimating the pressure that will be available at the worst case head, and 2) as a guideline when the irrigation design is completed to check total system pressure required and assure the system is designed correctly.
- **Estimated Pressure Available for Sprinkler Operation (line #20):** This is an estimate of the dynamic pressure available for sprinkler operation at the highest head in the system. If there is a significant drop in elevation to the location of other heads in the system, the pressure gain due to the drop in elevation could be added to this figure. This pressure should be used as a guide for selecting sprinklers. For example if the pressure on line #20 is 40 PSI, then sprinklers selected for the project should have operating pressures at 40 PSI or less.

After the preliminary design has been completed, a thorough calculation of the friction loss in the system should be made before committing to the final irrigation plan. This calculation should include friction loss in the lateral lines and all other components back to the point of connection, and should be based on the GPM actually expected to be used by the sprinkler heads chosen. This subject is covered later under “Friction Losses”.

D. Estimate Pressure Available at “Worst-Case” Head

21 Pressure change due to elevation change from the POC to the highest head in the system. _____ ft. x 0.433 = _____ PSI

22 Pressure subtotal (subtract Line 21 from Line 20; for worst case heads which are lower than the POC, add Lines 20 and 21) _____ PSI

23 Estimated Pressure Available at worst case-head two-thirds of subtotal: Line 22 _____ PSI x 0.67 = _____ PSI

Pressure Available for Sprinkler Selection and Operation _____ PSI

*Although this is referred to as static pressure, in municipal systems it is taken to mean the minimum dynamic pressure at the water main.



(METERED SYSTEMS)
**Design Capacity and Working Pressure
Worksheet**

CALCULATING DESIGN CAPACITY AND DYNAMIC PRESSURE

A. Record Site Information

1 Static* Pressure at the Source (Main)	_____	PSI
2 Net elevation Change (Source to POC) ± uphill, - downhill)	_____	FEET (+)
3 Pressure change due to elevation: Line 2 x 0.433 =	_____	PSI
4 Static Pressure at POC: Line 1 +/- Line 3 =	_____	PSI
	<i>Number/Length</i>	<i>Size</i>
5 Service Line	_____	_____
6 Delivery Line	_____	_____
7 Water Meter	_____	_____
8 Isolation Valves	_____	_____
9 Other	_____	_____

B. Determine Design Capacity

	<u>Factor</u>	<u>Restriction</u>	<u>GPM With Restriction</u>
10 Pressure loss through the water meter.		Not to exceed 10% of available PSI at the source(Line 1)	_____ GPM
11 Volume through the water meter.		Not to exceed 75% of maximum safe flow of the meter.	_____ GPM
12 Velocity through the service line.		Velocity not to exceed 7.5 fps (Main to meter)	_____ GPM
13 Design Capacity	Lowest GPM of the three flows rates - lines 10, 11, and 12.		_____ GPM

C. Calculate Dynamic Pressure at Design Capacity

Pressure Losses from Source(City Water Main) to the POC

14 Pressure loss in the Service Line	_____ PSI loss (per 100') x	_____ ft./100 =	_____ PSI
15 Pressure loss in the Delivery Line	_____ PSI loss (per 100') x	_____ ft./100 =	_____ PSI
16 Pressure loss in the Water Meter at design capacity		=	_____ PSI
17 Pressure loss in the Gate Valves:	_____ Equivalence Factor		
	x _____ PSI loss per 100' of		
	_____ Standard Steel/100		
	x _____ Number of Gate Valves	=	_____ PSI
18 Other pressure losses _____		=	_____ PSI
19 Pressure loss from the source to POC (add Lines 14 through 18)			_____ PSI
20 Approximate Dynamic Pressure at Design Capacity			
Static Pressure at the POC (Line 4 above)			_____ PSI
Subtract the PSI lost from the source to the POC (Line 19)			_____ PSI
Approximate Dynamic Pressure at Design Capacity			_____ PSI



D. Estimate Pressure Available at “Worst-Case” Head

21 Pressure change due to elevation change from the POC to the highest head in the system. _____ ft. x 0.433 = _____ PSI

22 Pressure subtotal (subtract Line 21 from Line 20; for worst case heads which are lower than the POC, add Lines 20 and 21) _____ PSI

23 Estimated Pressure Available at worst case-head two-thirds of subtotal: Line 22 _____ PSI x 0.67 = _____ PSI

Pressure Available for Sprinkler Selection and Operation _____ PSI

*Although this is referred to as static pressure, in municipal systems it is taken to mean the minimum dynamic pressure at the water main



(METERED SYSTEMS)
**Design Capacity and Working Pressure
Worksheet**

CALCULATING DESIGN CAPACITY AND DYNAMIC PRESSURE

A. Record Site Information

1 Static* Pressure at the Source (Main) _____ PSI
2 Net elevation Change (Source to POC) ± _____ FEET (+ uphill, - downhill)
3 Pressure change due to elevation: Line 2 x 0.433 = _____ PSI
4 Static Pressure at POC: Line 1 +/- Line 3 = _____ PSI

	<i>Number/Length</i>	<i>Size</i>	<i>Type</i>
5 Service Line	_____	_____	_____
6 Delivery Line	_____	_____	_____
7 Water Meter	_____	_____	_____
8 Isolation Valves	_____	_____	_____
9 Other	_____	_____	_____

B. Determine Design Capacity

	<i>Factor</i>	<i>Restriction</i>	<i>GPM With Restriction</i>
10 Pressure loss through the water meter.		Not to exceed 10% of available PSI at the source(Line 1)	_____ GPM
11 Volume through the water meter.		Not to exceed 75% of maximum safe flow of the meter.	_____ GPM
12 Velocity through the service line.		Velocity not to exceed 7.5 fps (Main to meter)	_____ GPM
13 Design Capacity Lowest GPM of the three flows rates - lines 10, 11, and 12.			_____ GPM

C. Calculate Dynamic Pressure at Design Capacity

Pressure Losses from Source(City Water Main) to the POC

14 Pressure loss in the **Service Line** _____ PSI loss (per 100') x _____ ft./100 = _____ PSI
15 Pressure loss in the **Delivery Line** _____ PSI loss (per 100') x _____ ft./100 = _____ PSI
16 Pressure loss in the **Water Meter** at design capacity = _____ PSI
17 Pressure loss in the **Gate Valves**: _____ Equivalence Factor
x _____ PSI loss per 100' of Standard Steel/100
x _____ Number of Gate Valves = _____ PSI
18 **Other** pressure losses _____ = _____ PSI
19 Pressure loss from the source to POC (**add** Lines 14 through 18) _____ PSI
20 Approximate **Dynamic Pressure at Design Capacity**
Static Pressure at the POC (Line 4 above) _____ PSI
Subtract the PSI lost from the source to the POC (Line 19) _____ PSI
Approximate Dynamic Pressure at Design Capacity _____ PSI



D. Estimate Pressure Available at “Worst-Case” Head

21 Pressure change due to elevation change from the POC to the highest head in the system. _____ ft. x 0.433 = _____ PSI

22 Pressure subtotal (subtract Line 21 from Line 20; for worst case heads which are lower than the POC, add Lines 20 and 21) _____ PSI

23 Estimated Pressure Available at worst case-head two-thirds of subtotal: Line 22 _____ PSI x 0.67 = _____ PSI

Pressure Available for Sprinkler Selection and Operation _____ PSI

*Although this is referred to as static pressure, in municipal systems it is taken to mean the minimum dynamic pressure at the water main.



D. Estimate Pressure Available at “Worst-Case” Head

21 Pressure change due to elevation change from the POC to the highest head in the system. _____ ft. x 0.433 = _____ PSI

22 Pressure subtotal (subtract Line 21 from Line 20; for worst case heads which are lower than the POC, add Lines 20 and 21) _____ PSI

23 Estimated Pressure Available at worst case-head two-thirds of subtotal: Line 22 _____ PSI x 0.67 = _____ PSI

Pressure Available for Sprinkler Selection and Operation _____ PSI

*Although this is referred to as static pressure, in municipal systems it is taken to mean the minimum dynamic pressure at the water main.



(PUMP SYSTEMS)

Design Capacity and Working Pressure Worksheet

CALCULATING DESIGN CAPACITY AND DYNAMIC PRESSURE

A. Record Site Information

- 1 Dynamic pressure at the discharge point _____ PSI
2 Pump available flow at discharge point _____ GPM
3 Net elevation change (discharge to POC) ± _____ FEET (+ uphill, - downhill)
4 Pressure change due to elevation: Line 3 x 0.433 = _____ PSI
5 Pressure at POC: Line 1 +/- Line 4 = _____ PSI

	<i>Number/Length</i>	<i>Size</i>	<i>Type</i>
6 Delivery Line	_____	_____	_____
7 Isolation Valves	_____	_____	_____
8 Other	_____	_____	_____

B. Determine Design Capacity

- | <u>Factor</u> | <u>Restriction</u> | <u>GPM With Restriction</u> |
|---|--|-----------------------------|
| 9 Pump/Well GPM capacity | Continuous supply available at discharge point (Line 2) | _____ GPM |
| 10 Pump Safety Factor | Not to exceed 90% of continuous supply available at discharge point _____ x 0.10 | |
| = | _____ | _____ GPM |
| 11 Design Capacity (subtract Line 10 from Line 9) | | _____ GPM |

C. Calculate Dynamic Pressure at Design Capacity

Pressure Losses from Discharge Point to the POC

- 12 Pressure reduction 10% as Pump Safety Factor _____ x 0.10 = _____ PSI
13 Pressure loss in the Delivery Line _____ PSI loss (per 100') x _____ ft./100 = _____ PSI
14 Pressure loss in the Isolation Valves: _____ Equivalence factor
x _____ PSI loss per 100' of standard steel/100
x _____ Number of valves = _____ PSI
15 Other pressure losses _____ = _____ PSI
16 Pressure loss from the discharge point to POC (add Lines 12 through 15) _____ PSI
17 Approximate Dynamic Pressure at Design Capacity
Dynamic pressure at the POC (Line 5 above) _____ PSI
Subtract the PSI lost from the discharge point to the POC (Line 16) _____ PSI
Approximate Dynamic Pressure at Design Capacity _____ PSI

D. Estimate Pressure Available at “Worst-Case” Head

- 18 Pressure change due to elevation change from the POC to the highest head in the system. _____ ft. x 0.433 = _____ PSI
- 19 Pressure subtotal (subtract Line 18 from Line 17; for worst case heads which are lower than the POC, add Lines 17 and 18) _____ PSI
- 20 Estimated Pressure Available at worst case-head two-thirds of subtotal: Line 19 _____ PSI x 0.67 = _____ PSI

Pressure Available for Sprinkler Selection and Operation

_____ PSI



(PUMP SYSTEMS)

Design Capacity and Working Pressure Worksheet

CALCULATING DESIGN CAPACITY AND DYNAMIC PRESSURE

A. Record Site Information

- 1 Dynamic pressure at the discharge point _____ PSI
2 Pump available flow at discharge point _____ GPM
3 Net elevation change (discharge to POC) ± _____ FEET (+ uphill, - downhill)
4 Pressure change due to elevation: Line 3 x 0.433 = _____ PSI
5 Pressure at POC: Line 1 +/- Line 4 = _____ PSI

	<i>Number/Length</i>	<i>Size</i>	<i>Type</i>
6 Delivery Line	_____	_____	_____
7 Isolation Valves	_____	_____	_____
8 Other	_____	_____	_____

B. Determine Design Capacity

- | <u>Factor</u> | <u>Restriction</u> | <u>GPM With Restriction</u> |
|---|--|-----------------------------|
| 9 Pump/Well GPM capacity | Continuous supply available at discharge point (Line 2) | _____ GPM |
| 10 Pump Safety Factor | Not to exceed 90% of continuous supply available at discharge point _____ x 0.10 | |
| = | _____ | _____ GPM |
| 11 Design Capacity (subtract Line 10 from Line 9) | | _____ GPM |

C. Calculate Dynamic Pressure at Design Capacity

Pressure Losses from Discharge Point to the POC

- 12 Pressure reduction 10% as Pump Safety Factor _____ x 0.10 = _____ PSI
13 Pressure loss in the Delivery Line _____ PSI loss (per 100') x _____ ft./100 = _____ PSI
14 Pressure loss in the Isolation Valves: _____ Equivalence factor
x _____ PSI loss per 100' of standard steel/100
x _____ Number of valves = _____ PSI
15 Other pressure losses _____ = _____ PSI
16 Pressure loss from the discharge point to POC (add Lines 12 through 15) _____ PSI
17 Approximate Dynamic Pressure at Design Capacity
Dynamic pressure at the POC (Line 5 above) _____ PSI
Subtract the PSI lost from the discharge point to the POC (Line 16) _____ PSI
Approximate Dynamic Pressure at Design Capacity _____ PSI

D. Estimate Pressure Available at “Worst-Case” Head

- 18 Pressure change due to elevation change from the POC to the highest head in the system. _____ ft. x 0.433 = _____ PSI
- 19 Pressure subtotal (subtract Line 18 from Line 17; for worst case heads which are lower than the POC, add Lines 17 and 18) _____ PSI
- 20 Estimated Pressure Available at worst case-head two-thirds of subtotal: Line 19 _____ PSI x 0.67 = _____ PSI

Pressure Available for Sprinkler Selection and Operation

_____ PSI



Sprinkler Selection

Introduction

The multitude of variables in sprinkler characteristics and features can make head selection a daunting task for first time designers. While there is no single method of head selection that works in all situations, this section of the design manual will provide a step-by-step process for choosing the best sprinkler for the area. If the designer follows this method in the order presented it will narrow the list of acceptable heads to a limited number for final selection.

The first step in the process is to have a good understanding of the types (categories) of sprinklers available. Then, knowing what category each sprinkler fits in to, choosing the correct sprinkler becomes easier; you select a category which contains just a few sprinklers, then you select a sprinkler within that category.

Types of Landscape Sprinklers

Generally speaking, there are three different types, or categories of sprinklers which are most commonly used on the smaller irrigation projects. Drip is used in some areas of the country, but it is not as widely accepted as the three categories that we will discuss in this section.

- 1) Bubblers
- 2) Sprays
- 3) Gear Drive Rotors

Bubblers

Bubblers are designed to apply a large amount of water to a small area in a short period of time. The bubbler delivers water to the area immediately around the head (umbrella bubbler), or is sprayed in thick streams a short distance from the bubbler (stream bubbler). Because of this high flow rate and close spacing requirements, bubblers are restricted to small, confined, level areas. Bubblers operate over a pressure range of 1 to 90 PSI and may be used on most types of plant material with the exception of turf.

Sprinkler Type	Typical Uses	General Characteristics	Advantages	Disadvantages
Bubbler - Flood or Stream	Small, level areas with perimeter containment.	Heads provide a large volume of water in a small area to “flood” plant material basins.	Provides a large quantity of water in a short period of time.	Very high flow rate will result in run-off if the area isn’t level and the water isn’t contained.
Bubbler - Pressure Compensating	Small, level areas where a lower flow rate or pressure compensating is needed	Heads provide a lower amount of water in a small area directly to plant basins.	Reduces runoff. Lower flow rate allows water to be absorbed into soil. Pressure compensating feature maintains even flow	Lower flow rate requires longer run times.

Spray Heads

Fixed spray heads may be used for almost any type of landscape planting – from turf and ground cover to shrub beds and planters. The shorter radius (5-17 ft.) of lawn and shrub fixed spray heads make for a high level of control for over-spray, but their relatively short radius also limits their usefulness to smaller areas. Spray heads typically have flow rates of up to 5-1/2 GPM or more. This high flow rate restricts the use of the heads to relatively level areas to prevent runoff.

Stream spray heads provide a slightly larger radius. Stream spray heads have been successfully used on gentle slopes because the GPM is slightly lower, while the radius is slightly larger, reducing the risk of run-off. Caution should be exercised when using stream spray heads in shrub beds because shrub branches can block the relatively small spray streams.

The pressures for most spray heads range from 15 to 50 PSI. Particular attention should be paid to situations with excess pressure, which produces severe misting and poor water distribution.

Sprinkler Type	Typical Uses	General Characteristics	Advantages	Disadvantages
Shrub - Fixed Spray PS SRS Pro-Spray I-Spray	Installed on Stationary risers for use in shrub beds, ground cover areas or on slopes.	Fixed spray head on riser without pop-up capability - typically made of plastic.	Provides the ability to install on fixed riser above the plant material.	Not recommended for areas with pedestrian traffic because of tripping hazard. Small radius typically limits use to smaller areas.
Pop-up Fixed Spray PS SRS Pro-Spray I-Spray	Widely used for turf, ground cover, and shrub beds.	Pop-up capability ranging from 2" to 12" - typically made of plastic.	Pops up above turf and ground covers. Pop-up heads now commonly used anywhere foot traffic is a concern such as near walkways.	Gravity retraction or light weight retraction springs on some brands may cause heads to stick in up position. Select models with heavier-duty, more positive spring assisted retraction.

Gear Driven Rotors

Gear drive rotor heads are well suited for medium to large landscapes with most types of plantings. Their larger radius (15-74 ft.) make rotor heads a frequent choice for medium to large landscape areas.

The relatively low GPM for the area of coverage is less than spray heads and makes them useful on landscapes from level to steeply sloping. Lower flows allow more sprinklers to be operated at one time, reducing the number of zone control valves and controller stations (more area can be covered on a single zone). Additionally, less pipe and labor are necessary with rotor systems than with spray systems, which reduces the over-all system installed cost.

Typically, designers want to use the largest head possible for the most efficient and the lowest cost system. Pressure requirements for rotors range from 25 to 100 PSI.

Sprinkler Type	Typical Uses	General Characteristics	Advantages	Disadvantages
Small Area Rotor - PGJ	Turf, ground cover and shrub beds.	Pop-up head with internal gear drive. Radius range from 15 ft. to 25 ft.	Brings advantages of full size gear rotors to mid-range radius head. Multiple nozzle sets, variable arc. The PGM can be installed on the same zone as PGP or I-20.	PGJ rotors should not be used in areas smaller than 11 or 12 feet.
Full size Gear Rotor - Shrub PGS I-10	Installed on stationary risers for use in shrub beds, ground covers areas or on slopes.	Gear drive heads have one or more nozzles that provide larger radius than possible with fixed spray heads.	Multiple nozzle sets for various pressure and radius situations. Relatively low flow requirements for the area of coverage.	Full sized rotors are designed to be used in larger areas.
Full Size Gear Rotor - Pop-up PGP I-20 I-25 I-40	Turf, ground cover and shrub beds and slopes.	Internal gear drive, typically larger nozzle openings provide greater radius than fixed spray or small-area rotor.	Multiple nozzle sets for various pressure and radius situations. Relatively low flow requirements for the area of coverage.	Full sized rotors are designed to be used in larger areas.

Selecting the Proper Sprinkler

Now that you have an understanding of the three categories of sprinklers available, selecting the proper sprinkler for a project is simply a matter of analyzing the project and the areas to be watered.

The following are general rules-of-thumb for sprinkler selection. Remember, there will always be exceptions to these guidelines.

- 1) Pressure Limitations
- 2) Flow Limitations
- 3) Precipitation Rate
- 4) Large to Small Radius
- 5) Spray Patterns
- 6) Angles of Trajectory
- 7) Special Features

Pressure Limitations

The first consideration when choosing the correct sprinkler for an area is pressure. If the sprinkler's operating pressure is greater than the estimated dynamic pressure available (estimated dynamic pressure is discussed in the Design Capacity section of this manual) the sprinkler must be eliminated from the list of sprinklers to use. For example, our project has an estimated dynamic pressure of 50 PSI. For the larger area on this project, any sprinkler that has an operating pressure over 50 PSI for the 35 ft. radius needed would be scratched from the list of available sprinklers.

Operating Pressure and Head Selection. The operating pressure is the pressure range that provides optimum sprinkler performance. Hunter establishes the range of operating pressures for our sprinklers and publishes those specifications in our catalogs and other product literature.

When selecting a sprinkler the operating pressure must be less than the estimated dynamic pressure available for the project. Operating pressures range from as low as 1 to 2 PSI for some bubbler heads to as high as 100 PSI in large turf rotor heads.

Too Little or Too Much Pressure. Attempting to use sprinklers for which there is insufficient pressure results in distorted spray patterns or failure of the sprinkler to operate. Applying too much pressure to a head can cause fogging, misting or structural damage to the sprinkler head. In general, it is easier to deal with a system that has too much pressure than one with insufficient pressure. Operating pressures that are too high or too low will result in uneven water distribution and poor plant growth.

What To Do for Insufficient Pressure. When insufficient pressure is available for the sprinkler head chosen, there are several alternatives:

- ◆ check system pressure losses to determine if sufficient pressure can be conserved elsewhere in the system
- ◆ select an alternative nozzle for the sprinkler that operates at a lower pressure (Note: this may affect head spacing and layout)
- ◆ select an alternative sprinkler model with a lower operating pressure
- ◆ install a booster pump (Note: this is usually the last choice because of the high initial cost and continuing operating expenses associated with booster pumps.)

What To Do With Too Much Pressure. When there is too much pressure, the pressure may be reduced with a pressure regulator for the entire system, or with a pressure regulator built into the control valve (such as Hunter's ICV). In many cases, minor pressure reductions may be made using the valve's flow control.

Flow Limitations

The "Design Capacity" that was determined earlier may limit the selection further. For example: our project has a design capacity of 14 GPM. Efficient irrigation designs will usually have at least 3 or more heads per control valve. Using that rule-of-thumb, 14 GPM divided by 3 equals 4.6 GPM as the maximum GPM per sprinkler. Those sprinklers or nozzles with flow rates in excess of 4.6 GPM should be dropped from consideration.

Sprinkler Flow Rates and Head Selection. In irrigation system design, the water available for irrigation on a project is limited to the design capacity. Once the amount of available water (design capacity) is established, sprinkler heads that have flow rates of one third the design capacity or less are selected. The flow rates are published in Hunter's catalogs and specification sheets. These flow rates will vary for each type of sprinkler depending on the operating pressure. It is important to remember the pressure being used for the design should be no more than the estimated pressure from the design capacity worksheet.

Selecting sprinklers with flow rates of 1/3 or less of design capacity allows the use of at least three heads per control valve. This reduces system cost by keeping the number of control valves to a minimum. For example: if the design capacity for a project is 18 GPM, sprinklers with a flow rate of 6 GPM or less would be preferred (3 heads x 6 GPM = 18 GPM, which is within the 1/3 range of the design capacity). There are exceptions to this general rule, but in most cases, if there are less than three heads per control valve the system cost will increase substantially.

Precipitation Rate

Expressed in inches per hour (in/hr), precipitation rate is the rate at which water is being applied. Large area rotors and small area sprays may use the same GPM, but because the size of the areas they cover are not the same, the inches per hour of water applied is very different. Precipitation rate affects sprinkler selection and irrigation scheduling. Site conditions, including slopes or slow soil infiltration rates, may require low precipitation rate heads or nozzles (less than 0.50 in./hr.). If low precipitation rates are necessary for the area, eliminate the higher precipitation rate heads.

Rule: Never install sprinklers with different precipitation rates on the same zone.

Precipitation Rate and Runoff. Caution must be used when selecting high precipitation rate sprinklers (over 1.0 in./hr.) for use on areas with slopes. Precipitation rates that exceed soil infiltration rates on sloping soils can result in runoff. While it is not always possible to select a sprinkler with a precipitation rate lower than soil infiltration rate, low precipitation rate sprinklers will reduce the potential for runoff and allow longer run times per cycle.

Sprinklers are generally described as either :

- Low Precipitation Rate - Less than 0.50 in/hr
- Moderate Precipitation Rate - 0.50 to 1.0 in/hr
- High Precipitation Rate - More than 1.0 in/hr

The chart below shows the range of precipitation rates found in common sprinkler types. Sprinkler types may fall into more than one category depending on the nozzle selected.

TYPICAL PRECIPITATION RATE RANGES				
	LOW	MODERATE	HIGH	
BUBBLERS			1-1/2 to	12 in./hr.
FIXED SPRAYS			1 to 5 in./hr.	
GEAR DRIVE ROTORS	0.1 to	1.0 in./hr.		
	0.1	1.0	2.0	

Precipitation Rate versus Sprinkler Run Time. In discussions of precipitation there is often a misconception about longer run times associated with low precipitation rate sprinklers. The amount of time required to irrigate a project is not typically affected by the sprinkler precipitation rate. While it is true that each low precipitation rate head must be run for a longer period of time, more heads can be installed on a zone and, therefore, the total irrigation time for an entire project will be the same for high precipitation-rate heads with many zones, and low precipitation-rate heads with few zones.

Similar run times can be confirmed by checking the design capacity. If designs with both high and low precipitation-rate heads use the maximum flow rate available for the project (design capacity) then both projects will have similar total run times.

Sprinkler Radius

Distance of throw is one of the most important criteria in sprinkler selection. Since the area to be irrigated cannot be changed, the sprinklers must fit the area. It is usually more cost effective to use fewer sprinklers, so the sprinklers with the largest radius that can be used is a major consideration. For example, when the smaller of the two dimensions of an area to be watered is 35 feet, a sprinkler with a radius that cannot be adjusted to 35 feet or less would be deleted from the list of possible heads for the area.

Head Selection Criteria With Regard to Radius. The following questions should be answered in order to select the best sprinkler for a project.

- ◆ What is the largest radius head that can be used in this area?
- ◆ Is the perimeter straight or curved and irregular?
- ◆ Is there sufficient pressure to operate large radius sprinkler heads?

Large Radius vs. Small Radius Sprinklers. As a general rule, using large radius sprinklers on a project will result in less initial system cost. For example using several valves and numerous 15 ft. radius fixed spray heads on a football field would be considerably more expensive than using half-a-dozen valves and a few 60 ft. radius full-size gear drive rotors.

Since using the head with the largest possible radius generally saves money on system installation, one of the main steps in selecting a sprinkler is to determine the largest sprinkler radius that can be used on the area without excessive over-spray; small radius sprinklers tend to provide coverage with less over-spray in small areas or areas with irregular perimeters. To determine the largest radius that can be used in an area, the dimension of the shorter side should be considered.

Generally, for larger areas a larger radius sprinkler is chosen. In some cases, large areas with irregular perimeters may have large radius sprinklers in the interior with smaller radius sprinklers along the edges. If the sprinklers in the smaller areas have a different precipitation rate than those in the larger area they must be valved separately so sprinkler run times can be adjusted to provide equal water application.

The range of radius covered is, in part, determined by the type of sprinkler. Small area spray heads are limited to about 17 feet while full sized gear rotors have a radius range of up to 100 feet.

Hunter®

Sprinkler Watering Patterns

Most sprinklers distribute water in a circular pattern. For these sprinklers the “pattern” refers to the portion of a circle covered by the sprinkler. The spray patterns typically available for sprinklers are as follows:

1) Fixed Arc - The fixed arc patterns are set portions of a circle such as: full is 360°; three-quarter is 270°; two-thirds is 240°; half is 180°; one-third is 120°; and quarter is 90°. Some manufacturers include other arcs in addition to these common patterns while other sprinklers may not be available in as many settings.

2) Adjustable Arc - Adjustable arc sprinklers can be adjusted to accommodate any landscape including the popular meandering, or curved lawns and ground covers. Hunter’s adjustable arc patterns are available in either the smaller area spray sprinklers or the larger area gear drive rotors. This adjustable arc feature provides additional flexibility in obtaining coverage in odd shaped landscape areas.

Many contractors now use 100% adjustable arc products on their sites to assure custom-tailored watering and to reduce the need to stock multiple parts.

3) Strip Spray Patterns - Fixed pattern spray heads are also available in rectangular patterns. While a rectangular pattern may seem ideal for small, narrow landscape areas it is difficult to maintain satisfactory water distribution when using strip spray heads. These heads should be used with this potential drawback in mind.

4) Stream Spray Patterns - Stream sprays distribute the water as small distinct streams as opposed to solid spray patterns. The advantage of the stream spray is a lower precipitation and flow rate as well as a slightly larger radius than fixed spray heads. Caution should be used where plant material might disrupt the small streams.

Angles of Trajectory

The trajectory range for most sprinklers is from 0° to 35°. Hunter offers sprinklers with standard trajectories ranging from 18° to 28° and low angle trajectories from 13° to 15°, depending on the model sprinkler. Some considerations for choosing low angle trajectory sprinklers are as follows:

1) *Distance of throw* - Low angle heads typically have a smaller radius and higher precipitation rate than standard trajectories for the same head or nozzle.

2) *Wind* - The amount of spray pattern distortion caused by wind is less with a low angle head than one with a standard trajectory.

Hunter®

3) *Spraying under barriers* - Low angle heads are sometimes used where the objective is to have the spray pattern below the low hanging branches and foliage of trees or large shrubs.

Special Sprinkler Features

Many times the installation will require a sprinkler with a special feature such as side inlets, variable arcs, or a built-in check valve to reduce low head drainage. The following are some of the most popular special features on many sprinklers and should be reviewed when choosing sprinklers.

- ◆ **Built-in Check Valves** - This feature will prevent water drainage or puddling at heads located at the lowest elevation on the circuit or zone. Check valves in these sprinklers typically provide low head drainage protection for heads from 7 to 15 feet below the highest head.
- ◆ **Reclaimed Water Identifier** - Purple identification caps may be added to identify the sprinkler water source as reclaimed water.
- ◆ **Built-in Filter** - Filters built into the body of the sprinkler are common in sprinklers with small water flows or small orifices.
- ◆ **Multiple Pop-up Heights** - The choice of sprinkler pop-up heights allows selection of a pop-up height from 2 inches to 12 inches. Higher pop-up heights facilitate irrigating in ground covers or low shrubs.
- ◆ **Side/Bottom Inlets** - On higher pop-up models (typically 6 inch or more) a side inlet may be available. The side inlet allows the taller pop-up body to be installed with the lateral line buried at a shallower depth than the overall height of the sprinkler body.
- ◆ **Adjustable Arc** - Adjustable arcs have been standard features of gear drive and impact drive rotors for years. More recently, manufacturers have developed adjustable arc spray heads. The adjustable arc reduces the need for numerous sprinklers of various arc patterns, thereby simplifying inventories, installation and maintenance.
- ◆ **Adjustable Radius** - Most sprinklers are designed with radius adjustment. Sprinkler radius can be adjusted from 75% to 99% of normal full radius and is useful in reducing over-spray. A note of caution: reducing the radius may alter the uniformity of water distribution.

Choosing Nozzles for Gear Driven Rotors

When designing an irrigation system, it is important to ensure that the precipitation is even over each zone of coverage. Matched precipitation in a landscaped area is best achieved by zoning like arcs together (quarter heads with only quarter heads, half with only half, and full with only full, for example), and then matching the precipitation rate by adjusting the controller run times.

Matched precipitation can be accomplished by selecting the appropriate nozzles. When zoning together sprinklers that will have different arcs, the two criteria to consider are a sprinkler's flow and area of coverage.

Although you cannot achieve exact matched precipitation when mixing arcs, you can get very close by choosing nozzles according to the GPM, and spacing all the heads on a system the same distance apart (reducing the radius on the half and full to the approximate radius of the quarter).

The illustration depicts three different sprinkler heads with matched precipitation. In each case, one gallon per minute is applied to each quarter circle, and each quarter circle is the same size - precipitation is therefore matched.

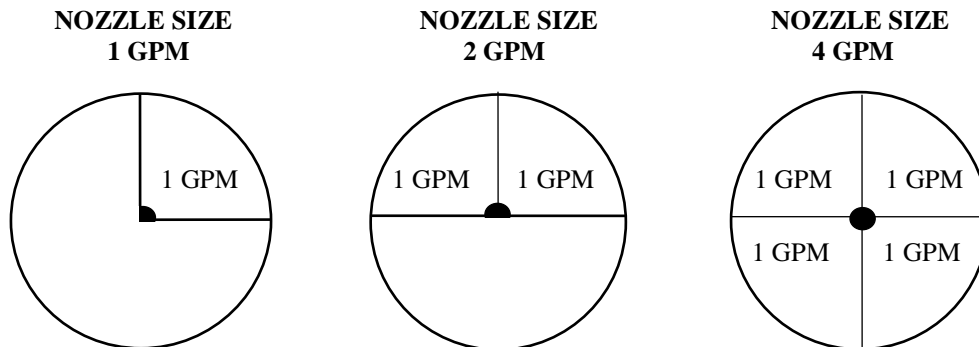

Figure 25

So, for heads with the same radius of throw, as the arc is increased, the flow rate of the nozzle should increase proportionally.

For nozzle selection in areas that will require odd arcs, such as 35° or 270°, use the following formula.

$$\text{GPM}_U = (\text{ARC}_U/\text{ARC}_K) \times \text{GPM}_K$$

Where:

GPM_U	is the flow rate (in GPM) of the unknown head
ARC_U	is the arc (in degrees) of the unknown head
ARC_K	is the arc (in degrees) of the known head
GPM_K	is the flow rate (in GPM) of the known head

Precipitation rates will be more thoroughly discussed in a later section.

Summary

The list of sprinklers available for designing a sprinkler system is huge. Throughout this section we have discussed various criteria for selecting the proper sprinkler for a particular use.

Use the product catalog and the following seven points to choose sprinklers. Remember, these are general rules-of-thumb; there will always exceptions to these guidelines.

- 1) **Pressure Limitations** - If the sprinkler's operating pressure is greater than the estimated dynamic pressures available, the sprinkler must be eliminated from the list of sprinklers to use. On higher pressure projects, pressure regulation may be necessary.
- 2) **Flow Limitations** - The Design Capacity that was determined earlier may limit the selection further. Efficient irrigation designs will usually have at least 3 or more heads per control valve. Using that rule-of-thumb, those sprinklers (or nozzles) with flow rates in excess of 1/3 of the design capacity should be dropped from consideration.
- 3) **Precipitation Rate** - Site conditions including slope and slow soil infiltration rates may require low precipitation rates (less than 0.50 in./hr.). If low precipitation rates are necessary for the area, eliminate the high precipitation rate heads such as sprays.
- 4) **Sprinkler Radius** - Since it is usually more cost effective to use less sprinklers, the sprinklers with the largest radius that can be accommodated in an area are considered first. Sprinklers with a radius that cannot be adjusted to the shortest distance in an area would not be placed on the list of possible heads for that area. (Large area rotors are typically used in areas that are larger than 25 feet, while small area rotors and sprays are usually placed in areas smaller than 25 feet.)

- 5) **Sprinkler Watering Patterns** - Be sure all heads remaining on the list have the necessary spray patterns for the area being watered.
- 6) **Trajectory** - If flat or low angle trajectories are necessary, further limit the list to those heads with optional low angle trajectories.
- 7) **Special Sprinkler Features** - The remaining heads should be reviewed to check for those needed special features such as side inlets, variable arcs or built-in check valves.

The list of sprinklers that meet the needed criteria for the area has now been narrowed to only the appropriate heads. Selection at this point will depend on your past experience, manufacturer warranty and support, and project budget.

The seven step checklist approach to head selection will take less time as you gain experience. With the added experience, you will often know the sprinkler to choose for a given area from the first glance at a design.

What You Need to Know

- Do not exceed the systems pressure or flow limitations when choosing sprinklers.
- Never mix sprinklers with different precipitation rates on the same zone.
- Consider the sprinkler's precipitation rate versus the soil's infiltration rate when choosing heads.
- Use the largest sprinkler available to cover the area. Using too many heads unnecessarily increases installation costs, while using too few heads leads to poor results and inadequate coverage in dry periods.
- The adjustable arc reduces the need for numerous sprinklers of various arc patterns, thereby simplifying inventories, installation and maintenance.
- Use sprinklers with low angle trajectories in areas where wind can be a problem, or where it is necessary to spray under low growing tree branches.

Sprinkler Placement

Introduction

The importance of proper sprinkler placement can not be over-emphasized. Once installed, if an irrigation system performs inefficiently, changing the nozzles or even the sprinklers may not be sufficient to correct the problem. And changing the sprinkler spacing after installation requires a great deal of additional time and money.

This section is designed to give an overview of head placement. Because design criteria and preferences vary from one geographical region to the next, no two designers will arrive at exactly the same placement pattern. The design criteria on some projects may emphasize sprinkler uniformity with minimal overspray while other projects may not be as concerned with uniformity and overspray as with system installation cost. Because of the varying design criteria and designer preferences, this section will provide a starting point for learning the art and science of head placement.

Key Factors

While there are different approaches to sprinkler head layout and spacing, certain factors must be considered for any placement plan. Key among these is the type and size of the planting areas (also called hydrozones), the manufacturer's maximum spacing ratings and the designers choice of spacing methods, and the effect of wind on those spacing values.

Hydrozones

A hydrozone is a portion of the landscape that has similar plants and/or water requirements. The hydrozone is irrigated by one or more valves using a common irrigation schedule. Before head placement can begin the designer must establish hydrozones, or areas with plants that would logically be watered on a similar irrigation schedule. Examples of hydrozones include an area of turf grass, a shrub bed, or a slope with ground cover.

The purpose of establishing hydrozones is to divide the landscape into areas that would use similar sprinkler equipment and can later be subdivided into circuits or zones. These circuits or zones are areas with the identical irrigation requirements. Subdividing the hydrozone into circuits or zones is presented later in the System Layout section. Once the hydrozones are established, the process of head spacing and layout begins.

Maximum Spacing Ratings

Traditional head spacing methods try to balance the need for uniform coverage and sufficient sprinkler overlap with the financial advantage gained by installing the fewest number of heads possible. This usually means installing the sprinkler with largest radius possible. (Large area rotors are typically used in areas that are larger than 15 feet, while small area sprays are usually placed in areas smaller than 15 feet.) The recommended sprinkler radius information is found in the Hunter Irrigation Products Catalog.

The traditional spacing methods are based on either square or triangular spacing patterns. The distance between sprinklers in a row and the distance between rows of sprinklers is based on the sprinkler's radius of throw. The distance is reduced as the average wind speed increases or as required by the distribution pattern of the sprinkler.

Square Spacing Patterns

In a square spacing pattern the sprinklers in a row are the same distance apart as the rows of sprinklers. It is sometimes considered that square spacing provides less uniform coverage than equilateral triangle spacing. However, in many small landscape areas it provides the best protection against overspray, and therefore is the preferred spacing pattern.

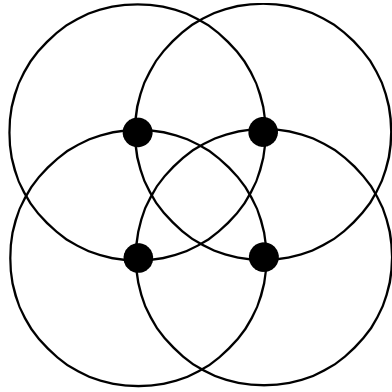

Figure 26

Triangular Spacing Patterns

In a triangular spacing pattern, the heads are placed at the corners of an equilateral triangle as shown. With triangular head spacing, the uniformity of coverage will be slightly higher than with square spacing patterns.

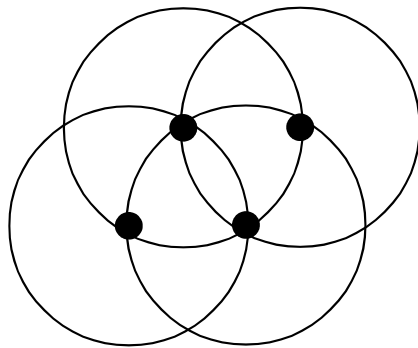
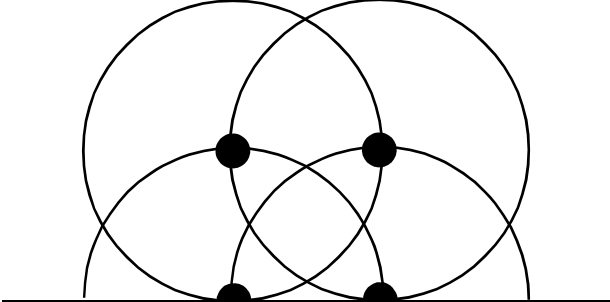

Figure 27

Triangular spacing is usually the preferred spacing pattern for large landscape areas. The major drawback to triangular head spacing is the tendency for more overspray along the perimeter, therefore it is seldom used in residential or other small area systems.

Square Spacing:



Triangle Spacing:

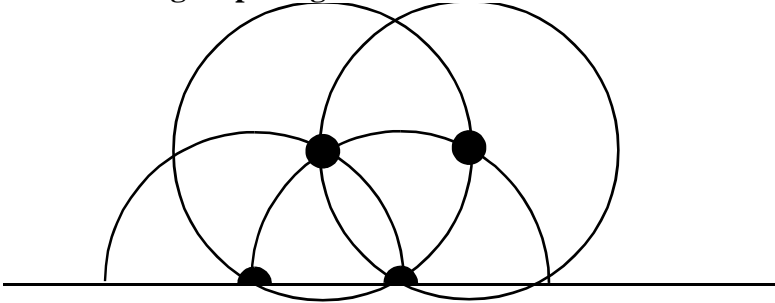

Figure 28

In both the square and the triangular methods, a minimum of **head-to-head spacing** is recommended (Figure 29).



Figure 29

The Effects of Wind

Sprinkler manufacturers recommend no more than head-to-head spacing in most situations. Additionally, manufacturers recommend watering in the early morning hours when the wind speed is at its lowest. The reality however, is that avoiding the wind may not be an option in all cases, and the spacing may have to be reduced to achieve even coverage.

Generally speaking, spacing at the manufacturer's recommended radius will provide even water distribution in light breezes of up to about 5 miles per hour. In areas where the wind is stronger than that, the spray pattern becomes distorted. A general rule of thumb is that for prevailing winds of more than 5 miles per hour, reduce the spacing by 1% for every 1 mile per hour.

In many areas where wind is a concern, low angle nozzles help to reduce wind drift and the resulting waste of water and uneven distribution.

Initial Sprinkler Layout

Whether based on square or triangular spacing methods, nearly every irrigated area will need some modification to the head and/or row spacing patterns. Achieving final head placement is the result of a process that includes:

- A) initial head layout based on the traditional head spacing methods and manufacturer recommendations.
- B) compression of head and/or row spacing as necessary to conform to site conditions
- C) placement of fill-in or supplemental heads, or heads with a larger or smaller radius

Sprinkler Placement Considerations

A) Consider the size of the hydrozone to find a placement pattern that provides uniform coverage while limiting the number of rows of sprinklers so that the cost of the installation is not prohibitive. For example, there may be sufficient pressure available to utilize a sprinkler that would cover the area with a single row placed in the middle of the area, but single row spacing results in poor water distribution uniformity and excessive overspray.

Distribution uniformity increases when two or more rows of sprinklers are used, but system installation cost increases with the additional rows. A good design will provide a balance of uniform coverage without an excessive number of sprinklers.

B) The flow and pressure available for the system will restrict the options available for sprinkler spacing. The lower the available pressure

Hunter®

and flow rate, the smaller the sprinkler radius. A smaller sprinkler radius results in shorter head and row spacing.

C) Selection of the sprinkler pattern that provides minimal overspray increases in importance if the irrigated area is bounded by public walkways, roadways, or parking areas, or if water conservation is an important consideration.

Placing the Sprinklers

Begin placing the sprinklers by locating appropriate part-circle sprinklers at all of the critical points of the area to be irrigated. Critical points are the corners of the area. For example, a relatively small square area has four critical points, where four quarter-circle heads would be located (see Figure 30).

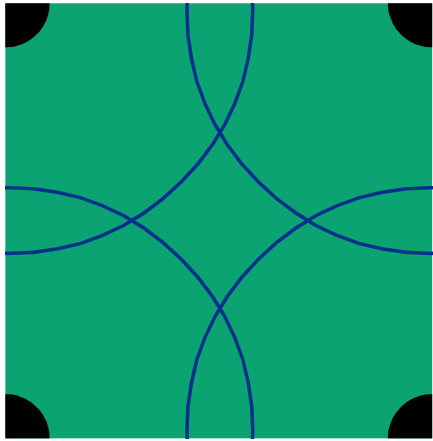

Figure 30

The next step is to measure the distance between adjacent critical points. If the distance between two sprinklers is within the spacing criteria established by the manufacturer, then no additional heads are necessary (head-to-head coverage). If the distance exceeds these spacing criteria, place a head within the recommended distance of one of the critical points (see Figure 31). Repeat this process around the edge of the entire area until there are enough part-circle heads to satisfy the spacing criteria.

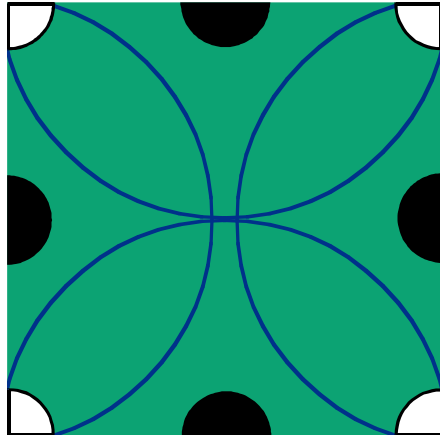

Figure 31

Now, if the coverage of the part-circle heads across the *width* of the area also does not meet the spacing criteria, then full-circle sprinklers need to be added along the *length* of the area. Locate these points by drawing a perpendicular line from each part-circle head, across the area, to the opposite head. Place full-circle sprinklers *at the intersections of these grid lines* (see Figure 32). Be sure to check the spacing along both the vertical and horizontal grid lines to ensure the spacing criteria are met in both directions.

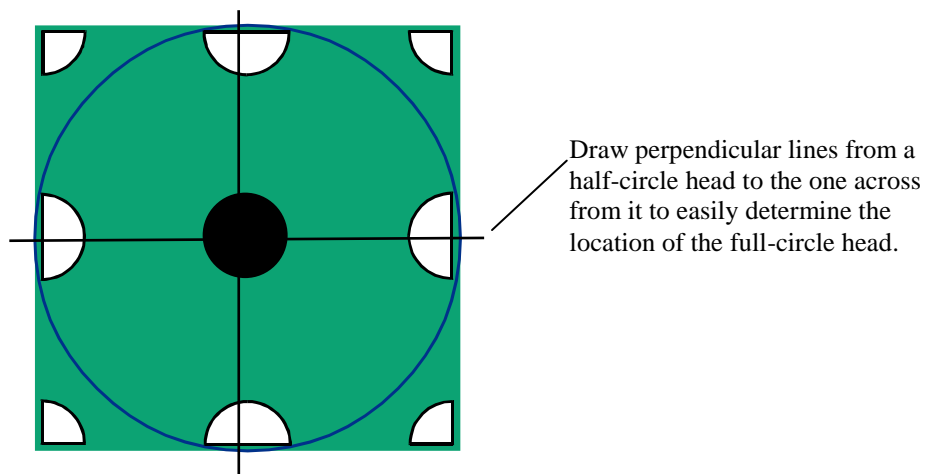

Figure 32

This method can be used to produce triangular spacing patterns as well. However, in this case, the grid lines will be diagonal instead of

perpendicular (see Figure 33). Many designers believe that triangular layouts provide better uniformity, but this may not always be the case. For example, a triangular pattern used in a rectangular area can reduce uniformity at the boundaries of the area.

So, a good rule of thumb when selecting a shape pattern is to use rectangular patterns for areas with right-angle corners, and triangular patterns for areas with odd-angle corners.

Note in Figure 33 that heads are placed at the intersection of two arcs.

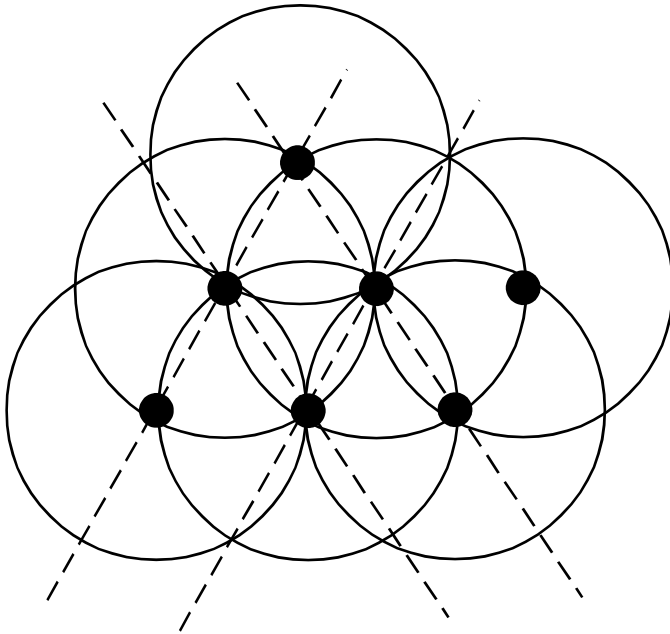

Figure 33

Curved Landscapes

The previous placing method is good for achieving uniformity in areas with definite corners. However, standard geometrical spacing is not suitable for all landscaped areas, especially those with curved shapes. In these cases, the critical points are the edges.

To design an irrigation system in a curved area, begin by placing sprinklers at the edges of the area, and then move inward toward its center. To determine these locations, convert the curved edge to a series of straight lines (see Figure 34); the length of the lines is determined by the sprinkler radius.

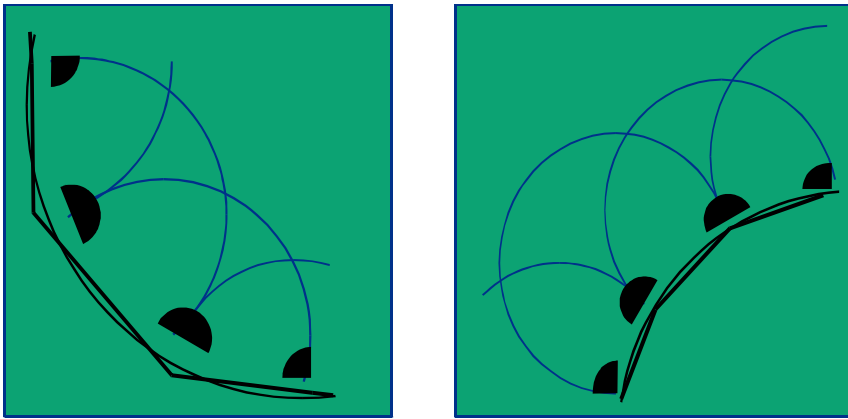

Figure 34

Next, place part-circle heads at each intersection of two lines. When this is done, full-circle heads are placed inside the area, from the perimeter toward the center of the area. Instead of using grid lines to place these interior heads, draw the circular spray pattern of each edge sprinkler, and evaluate its position using the spacing criteria of the manufacturer. Continue this process while moving toward the center of the area (see Figure 35).

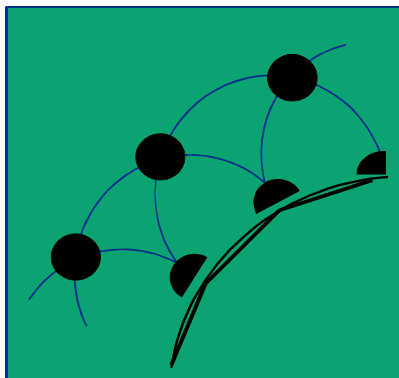

Figure 35

Most of the sprinklers placed inside the edges of the area will be full circles. If this does not provide adequate coverage, “back-up” heads may be required to achieve uniformity. These heads are not part of a

“symmetrical” layout, and they are placed to water areas that do not receive sufficient overlapping coverage from the other sprinklers.

Square, rectangular, and slightly curving landscape areas with no obstructions are the exception rather than the rule. Most landscape areas contain curves, obstructions, or size variations that make head placement more challenging. No two designers approach head placement for an area in the same way. With that in mind, the following are some typical problems faced by irrigation designers.

Solutions to the Design Problems

There are many solutions to every design problem. All of the solutions, however, will be undesirable to some degree depending on the design criteria.

- When designing for minimum cost, uniformity is jeopardized.
- When trying to reduce head count, overspray becomes a concern.
- Designing for maximum coverage with minimal overspray results in additional sprinklers and higher installation cost (lower operating costs may offset higher installation costs where water rates are high).

Sprinkler head layout is a process of selecting between conflicting design criteria and reaching a compromise. The following design solutions emphasize minimal overspray and maximum uniformity at the expense of additional sprinklers and higher initial expense.

Special Situations

Shrub Beds - Shrub beds where plants are spaced close together present the designer with the problem of dense foliage which blocks spray patterns.

With dense shrub beds the design options include: 1) shrub heads on tall risers to spray top of the foliage, 2) low angle trajectory nozzles to spray under the foliage, 3) bubblers in level areas with contained borders, or 4) drip irrigation. All of these solutions have their own limitations but represent possible options.

Protected Areas - Protected areas include: walks, patios, low windows, fences and walls.

For walks and patios the object is to minimize water onto these surfaces to limit safety hazards and reduce water waste. Depending on the size of the area, in general, smaller radius heads will result in less overspray than larger radius heads. In some cases where there are irregular boundaries on large landscape areas, small radius heads are used at the perimeter to protect the walks or other surfaces.

Windows that extend to the floor line present a special problem for designers. The window must be protected from spray drift or excessive maintenance will be required to remove accumulation or water spots. To minimize drift, 180° low angle spray heads are placed against the wall, spraying away from the window. This minimizes the drift of water back onto the window. If this is not sufficient, drip or bubbler irrigation in these areas is another option.

Fences and walls should be protected from direct spray to prevent fading or discoloration. Placing sprinklers 6 to 12 inches away from the fence or wall, and adjusting the sprinkler's pattern to spray out into the landscape will minimize the amount of water that comes into direct contact with them, and will reduce the amount of discoloration.

The Narrow Planter - A designer may be faced with a narrow planter that is smaller than the radius of most sprinklers. These areas are typical of planting strips around buildings and walkways where overspray can be a problem.

In a narrow area of turf, head placement can be difficult because of the number of heads that must be used in a small area to achieve uniform coverage. Because of the large number of heads in this small area the precipitation rate will be very high, which will require multiple short irrigation cycles to prevent runoff.

In shrub or ground cover areas, the number of heads needed can be reduced from the same sized turf area. This reduced-head layout may not provide adequate coverage for turf, but it can be appropriate for some ground covers and shrub beds.

Hunter[®]

Head spacing in narrow areas is determined by the size of the narrow area. Measure both areas, then divide the length of the narrow area into the length of the long area. This is the number of spaces between heads. Simply add 1 to the number of spaces to establish the number of heads needed for the area. When placing heads on the plan, place the first sprinkler along one side of the planter and place every other head on the opposite side of the planter.

A Wider Planter - A planting area of 15 to 20 ft. along the narrow side is more in line with the radius of throw for small rotors. The head layout would be similar to the narrow planter except that you can use small rotors (Hunter PGM). With this larger area the head count and precipitation rate would be acceptable.

The Curved Strip - A narrow curved area similar to a median area along a curving roadway can present a problem because the distance along the inside of the curve is less than the distance along the outside of the curve.

In a curved strip the head layout would be approached similar to the wider planter discussed above. The difference is the curve's inside radius is shorter than the outside radius. The designer would start by selecting a head that could cover the dimension across the narrow side of the area. The heads would then be placed along the inside curve at the appropriate spacing as determined by manufacturers recommendation, or by traditional spacing distances. The opposing row of heads placed along the outside edge of the curve would be placed using the same spacing (or compressed if necessary) without any attempt to keep the inside and outside heads aligned in a square or triangular pattern. Because of the difference in length of the inside and outside radii there may be fewer heads along the inside than along the outside of the curve. This type of placement provides for head-to-head coverage even though it is neither a true square or triangular pattern.

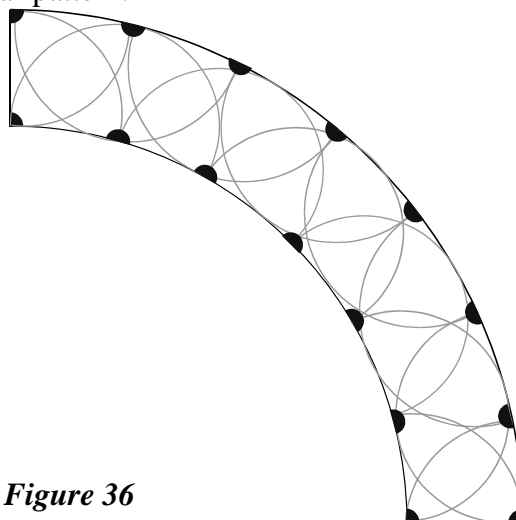

Figure 36

The Radius Edge - This type of area presents a problem because only one side is a radius. Normal head spacing must be adjusted or sprinklers with larger or smaller radius must be used.

Head placement in an area with a radius does not represent a true square or rectangular area either. Head placement must be adjusted to fit the curved edge while still maintaining head-to-head coverage.

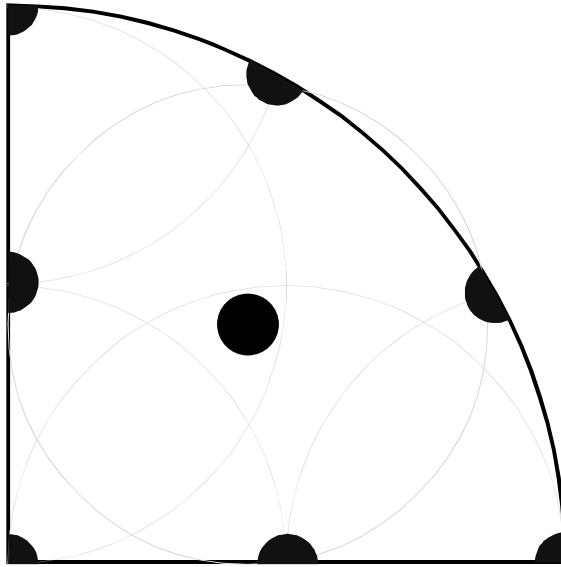

Figure 37

Short Radius Corner - This problem represents a portion of a larger turf area. The problem area is the corner that has a short radius.

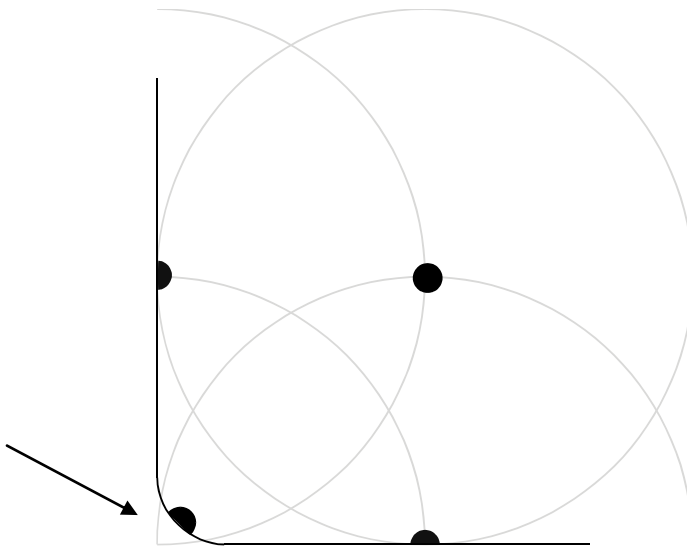

Figure 38

Head placement is complicated because the corner of this area is rounded instead of square. The designer must make a decision to either place a head outside of the planting area in a normal corner area position, center the head on the radius, or eliminate the sprinkler head.

A larger radius sprinkler can be very successful in a tight radius situation. Simply place an adjustable arc head in the corner, centered on the radius. While this does not provide perfect coverage, it delivers acceptable coverage for turf with minimal overspray. If the area is planted with shrubs, the head in the corner could be eliminated.

The Angled Border - In this situation the area starts out as a rectangle but the border on one side angles in to a narrower dimension. The challenge here is to use reduced radius heads to complete the head layout.

The head layout in this type of area can use rotor heads such as the PGP or I-20, with the radius reduced in the narrow end. Smaller nozzles can be used to obtain the reduced radius while maintaining a relatively uniform precipitation rate. If the area is too small for a reduced radius nozzle, a PGJ may be used on the same system. In order to maintain uniform application rates, the sprinklers along the perimeter may be placed on a separate valve(s) from the sprinklers in the middle of the area. Separate valves allow for longer sprinkler run-times for the heads in the middle which can contribute to an even distribution of water throughout the entire planting area.

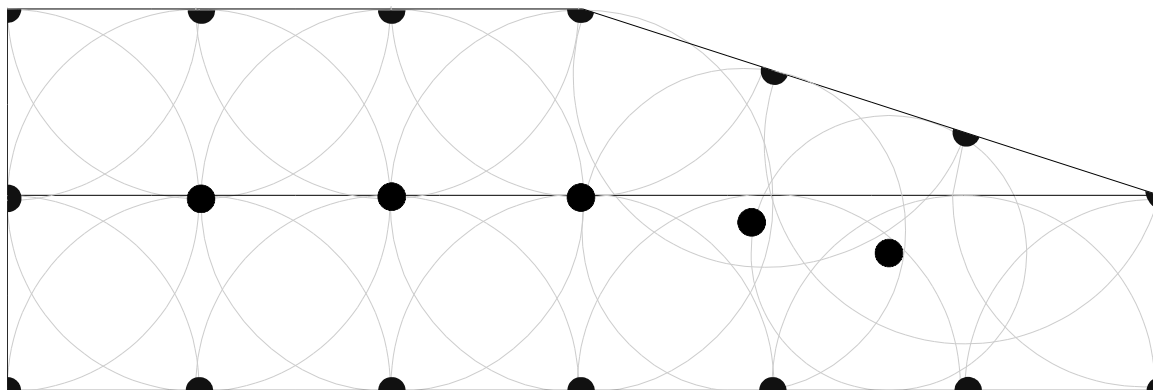

Figure 39

In a smaller angled landscape area, spray nozzles with a shorter radius can be installed in the narrower end.

The Curved Border - This problem includes a curving border that requires changing radius and/or types of heads in order to provide uniform coverage minimal overspray.

A possible solution for this problem would be to use fixed spray heads (Hunter PS or SRS) to provide uniform coverage with minimal overspray.

Another solution if the area is large with a tight curved border would be to use a combination of Hunter PGP or I-20 rotors and PGJ rotors on the same zone, or even Pro-Spray or I-Spray spray heads on a separate zone from the rotors. If you would need to use the spray heads, the use of the rotor heads in the same area substantially reduced the overall cost for the larger area even though the spray and rotor heads would have to be on separate valves. The difficult portion of this solution is to decide where to stop the spray heads and start the rotors.

PGP

Hunter[®]

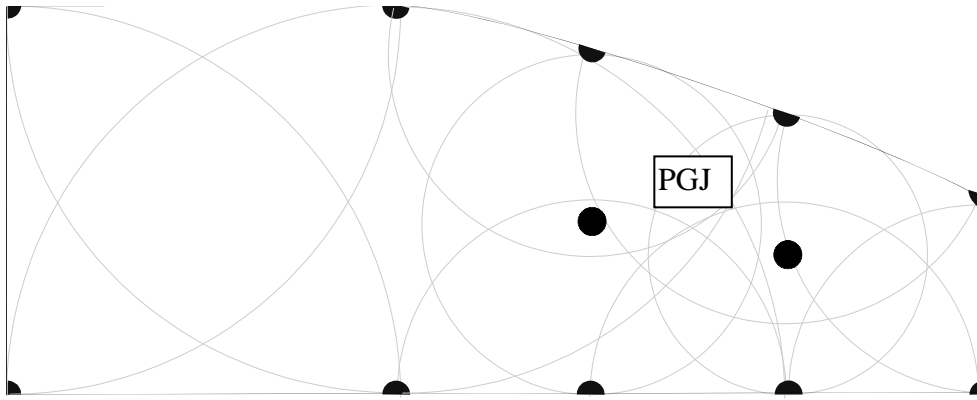

Figure 40

The Irregular Border - In this problem the border is neither straight nor a fixed radius. This wavy area forces the designer to make multiple nozzle selections and adjustments to head placement to accommodate the irregular boundary.

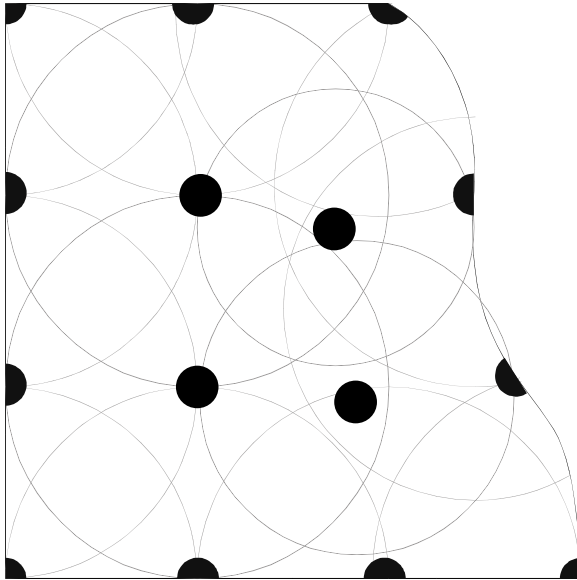

Figure 41

Like the Curved Border, because of the irregular boundary reduced radius heads would be implemented using smaller nozzles to maintain uniform precipitation rates. And, in order to maintain uniform application rates, the sprinklers along the perimeter would be on a separate valve from the sprinklers in the middle of the area. Separate valves allows for longer sprinkler run-times for the heads in the middle.

The Slope - In most sloped areas there are two challenges: the slope of the area and the fact the slope narrows at one end. This type of area is typical where a driveway enters an elevated property from a roadway. The narrow area requires an adjustment in the head spacing or radius of the heads. Additionally, the slope increases the potential for run-off and erosion.

Normally, the designer would choose low precipitation rate rotors for use on a slope. In some cases, a slope that is narrowed at one end makes the use of rotors impractical. Small radius spray heads can be used on the slope in order to accommodate those narrowing areas. Because spray heads have a high precipitation rate, the system would need a controller capable of watering using multiple short cycles to prevent excessive run-off and erosion (such as a Hunter ICC).

On larger slopes, a combination of rotors in the larger areas and sprays in the smaller areas with separate valves controlling the application of water can be a possible solution.

In order to provide greater control, three separate valves would be installed on the slope; one controlling the heads at the top of the slope, one for the middle heads, and one for the heads at the bottom of the slope.

Obstructions in the Landscape - With obstructions in the landscape, such as tree trunks, light poles or signs, care must be taken to prevent dry spots behind the obstruction caused by a blocked spray pattern. When obstructions are present, design options include: 1) adjusting head placement so the obstruction is at equal distance between adjoining heads or, 2) placing an additional fill-in head next to the obstruction spraying into the area where the spray pattern is blocked or 3) selecting larger radius heads where pattern is blocked in order to reach the dry spot.

Solutions to the problem of obstructions in the landscape require: 1) adjusting head placement so the obstruction is at equal distance between adjoining heads or, 2) placing additional fill-in heads near the obstruction spraying into the area where the spray pattern is blocked or, 3) selecting larger radius heads where pattern is blocked to reach the dry spot.

Residential Landscape: Adjoining Large and Small Areas - With this residential yard the designer is presented with the typical problem of a lawn area that has a small narrow area attached to a larger lawn area. In these situations, the designer must either maintain uniform precipitation rates in the large and small areas or separate valves must be used to accommodate the different precipitation rates when using different types of heads.

The small and large adjoining areas problem presents a difficult design situation which is common on small residential areas. The designer is faced with: 1) turf areas with east and west exposure which will require different irrigation schedules, 2) large and small turf areas that require different sprinkler types, 3) challenges to maintain uniform coverage with minimal overspray.

Hunter[®]

One solution to these problems is to use spray heads and rotors. Pro-Spray or I-Spray spray heads can be used in the smaller areas, while PGJ, PGP, or I-20 rotors can be in the larger areas. Separate valves are required for sprays and rotors.

If the smaller area is large enough (12 feet to 30 feet), PGJ rotors can be placed in that area with the PGP and I-20 rotors designed into the larger area. Because the two rotors have similar precipitation rates, both the small area and the large area rotors can be installed on one valve.

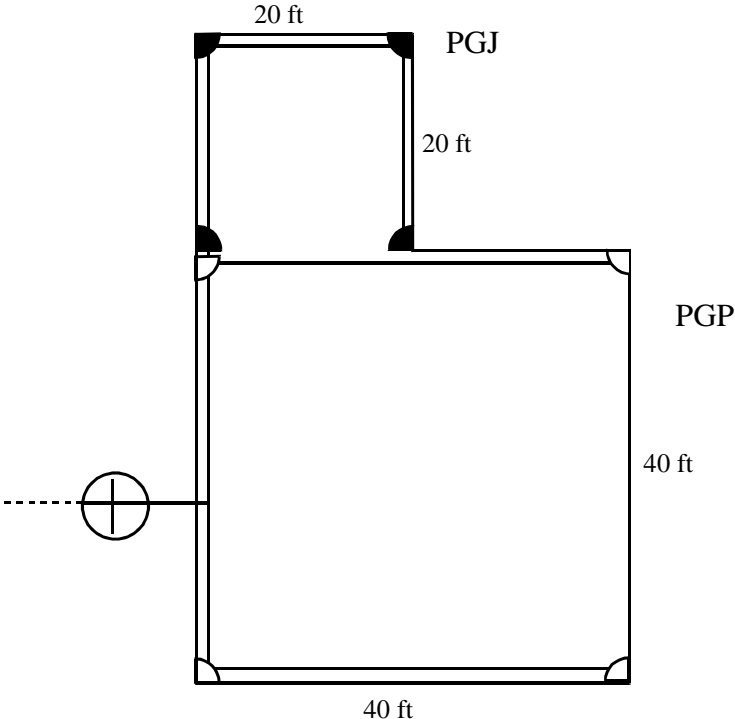

Figure 42

Summary

Sprinkler head placement is the most difficult and one of the most important steps in sprinkler system design. System uniformity, and installation and operating costs are determined by head placement plans.

Improved head placement will occur when:

1. manufacturer's recommendations are followed
2. careful analysis of head layout is included in the design process
3. head placement plans are compared with field installations

While no head placement plan will result in perfect water distribution uniformity, well thought out placement patterns will result in improved system performance and plant health over the lifetime of the irrigation system.

What You Need to Know

- Decide where you will be installing large area sprinklers and where you will be installing small area sprinklers.
- Always design your sprinkler systems with head-to-head coverage.
- Design the system by placing sprinklers in one area at a time.
 - The critical points are the corners. Mark the corners to receive heads, then using a compass, draw an arc showing the sprinkler's pattern.
 - If the quarter circle heads will not spray each other, place sprinklers along the perimeters. Draw these sprinkler's watering patterns.
 - If the perimeter heads will not spray across the area to the heads on the other side, add full circle heads in the middle. Draw these sprinkler's watering patterns.
- Minimal overspray and maximum uniformity is achieved at the expense of additional sprinklers and higher initial expense.

Sprinkler head layout is a process of selecting between conflicting design criteria and reaching a compromise. Your design solutions will be driven by the budget – with a higher the budget, your design can be more efficient.

Hunter®

Exercise

Transfer following two areas to your Hunter graph paper. Then, using Hunter PGJ rotors, place sprinklers in the appropriate locations.

Remember to start at the corners, then add heads as necessary. Assuming the available dynamic pressure at the sprinkler is 40 PSI, use the catalog to determine which nozzles to use.

Problem 1

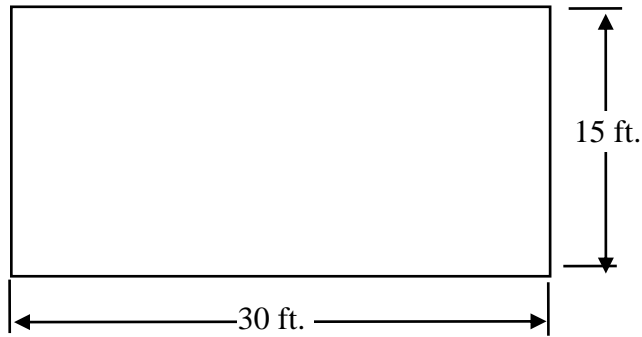

Problem 2

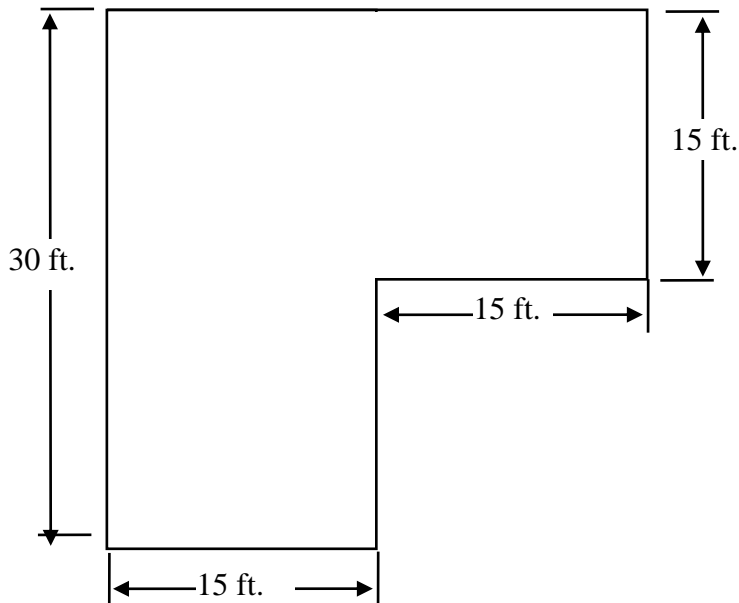

Backflow Prevention

Introduction

Backflow in sprinkler systems is the reversal of the flow of water from the sprinkler system back into the potable water system. This undesirable reversal of flow can draw contaminated water back into the drinking water system. There are many case studies where the backflow of contaminated water has caused severe and widespread illnesses, and in some cases deaths.

The intent of this section is to make you aware of the need for backflow prevention on all projects. Additionally, because you will understand the need of reducing this risk, you will have a better understanding of proper installation practices.

The following booklet on backflow preventers is very well written and includes a thorough discussion of what backflow is, and case studies to support the use of backflow prevention devices.

Various types of backflow prevention devices are discussed in the booklet. The Device Selection portion will help you decide which backflow preventer to use, and the Installation section provides you with details for the proper installation of each device.

As the various municipalities will require different types of devices, we recommend that in each separate area where you plan on installing a sprinkler system, you check the requirements for that area.

System Layout and Pipe Sizing

Introduction

Many hydrozone areas on a property will require more water than the property has available (system design capacity). The design pressure and flow must not exceed the calculated system design capacity and the pressure available for sprinkler selection and operation.

When backflow preventers, valves, or main line or lateral line pipe is sized too small, the system may experience water hammer. Severe water hammer will cause the pipes to vibrate or create a pounding noise. In extreme conditions, damage to the system may occur.

When the components are sized too large, the initial cost of the system is higher than necessary. Automatic control valves which are sized too large may not close due to the slow moving water.

This section discusses the procedures for correctly laying out and sizing the pipe and other components that go into a sprinkler system.

System Layout

Laying out a system begins with the information learned in the Sprinkler Selection and the Sprinkler Placement sections. Once the sprinkler locations for each hydrozone have been established, circuit the sprinklers into zones based on the design capacity as determined in the Design Capacity section. After the individual sprinkler zones have been established, connect the sprinklers together with pipe, size the pipe, and layout and size the valves and backflow preventer.

Circuiting Sprinklers Into Zones

Dividing the area into zones so that the design capacity is not exceeded is an easy process.

Working in one area at a time, write individual sprinkler GPM requirement next to each sprinkler in the area. Add up the GPM requirements for all sprinklers in one hydrozone, and divide by the total GPM (Design Capacity) available.

$$\boxed{} \div \boxed{} = \boxed{}$$

total GPM of all heads in one area design capacity in GPM number of zones in this area

If the “number of zones in this area” is not a whole number, round the number up to establish how many zones there will be. (1.2 zones becomes 2 zones.) This is the total number of valves needed for the sprinklers in that area.

If more than one zone will be needed for the area, divide up the sprinklers so that all zones in the area will have approximately the same GPM flow requirement. Don’t place too many heads on the same zone; stay within the system’s design capacity.

Repeat this process for each area on the property.

Backflow Preventer Location

Local plumbing codes govern the installation of backflow preventers. Usually, you will be required to place them in a position on the property where they are a minimum of 12” above the highest head. Check your local codes. Draw the location for the backflow preventer on the plan.

Main Line Location

In most systems, the main line will be under continuous pressure. Class 315 or Sch 40 PVC is the most common choice for main line pipe in these situations.

Determine the location for the point of connection (POC). Draw a line connecting all of the zone valve manifolds together, and then draw a line connecting this line to the backflow preventer, and then to the POC.

If the installation is in a freezing climate and the POC is in a basement, install a gate valve and a boiler drain immediately after the POC to drain the system in the winter. Install a slip x slip x 1 inch threaded tee with a riser and a threaded cap after the backflow preventer to be used for blowing out the system before the first deep freeze.

Copper pipe may be required between the POC and the backflow preventer. Always check the local plumbing codes for the requirements in your area. In general, above ground connections to backflow preventers should use metal pipe and fittings for durability and sunlight resistance.

Isolation Valve Locations

Isolation valves are great to use when performing maintenance on the zone control valves. On large commercial properties, it is not uncommon to place an isolation valve at each control valve manifold. On smaller properties, it is usually sufficient to place one main shutoff valve at the POC only. Many times, residential designers place isolation valves at the POC, and at both sides of a tee in a main line system for ease of maintenance.

Today’s low cost PVC ball valves make isolation valves for residential installations economically feasible easy to install. Note all isolation valve locations on the design.

Controller Placement and Wire Routing

Controllers (sometimes called clocks) are available in indoor mount and outdoor mount. Indoor mount controllers such as a Hunter SRC should be in a weatherproof enclosure or in an indoor location, such as a garage, shed, or covered porch, which is protected from moisture and direct sunlight. Outdoor-approved controllers can be mounted outside without an additional enclosure. An example of an outdoor-approved controller is a Hunter ICC-PL or a Hunter ICC-M

Indoor controllers should be mounted near a 120 volt AC outlet where the 24 volt plug-in transformer is connected. Outdoor controllers are frequently “hard wired” from the 120 volt source to the controller location. Hard wiring often requires the use of conduit – check local electrical codes for the type of wire and wire conduit to use.

For new construction, the controller location can be pre-planned and the 120 volt wiring can be installed in the wall before the wall is finished. The wire can then be installed through the back of the controller, in most cases eliminating the need for a conduit. Note the controller location and the 120 volt source on the plan.

The low voltage wire which runs from the controller to the valves is usually installed in the main line trench. You may want to indicate wire runs on your plan.

Wire connectors which are not exposed to moisture can be electrical “wire nuts” or insulated electrical connectors. Connections that will be located at the valves or in other areas subject to moisture should always be waterproof direct burial type. The low voltage control wire running from the controller to the valves should be rated for direct burial. This type of wire is available as an insulated single strand or as a jacketed multi-conductor. Either is acceptable for small irrigation systems, but the jacketed multi-conductor is generally less expensive.

Remote Control/Remote Programmer

A remote control can save time during installation and routine system maintenance. A receiver is installed at the controller, and a transmitter activates the sprinklers from a location on the property some distance from the controller. This allows the contractor or property owner to remotely activate a manual watering or system blow-out without the need to visit the controller.

There are a few different models of remotes available at various price points. The Hunter ICR receiver is plugged into an easy to hook-up wiring harness and can be used at up to 450 feet away from the receiver. Watering can be remotely controlled for all stations, or for one station at a

Hunter[®]

time. Station run time can be temporarily changed to permit custom operation. The ICR is very affordable and is available for use on Hunter SRC and ICC controllers.

Rain Sensor

Rain sensors are small sensing units which collect rainfall. They are used to stop the controller from sending the low voltage signal to the control valves during periods of rain.

Rain sensors are usually mounted near the controller on the eaves of a roof, or on a fence, away from possible irrigation interruption due to sprinkler water. Be sure to install the sensor away from obstructions so that rain can freely fall onto the sensor.

If a Hunter controller is not being installed, it is helpful to wire-in a bypass switch to turn off a sensor when its operation is undesirable (e.g. testing a system after rainfall). Hunter controllers have a built-in feature to accommodate this.

Hunter[®]

Pipe Sizing

You are now ready to begin sizing the pipe throughout the system. As previously mentioned, sizing pipes is a matter of friction loss management.

In many areas of the country, when installing a sprinkler system on a small residence, it is a standard practice to use just one size of polyethylene (poly) or PVC pipe for all lateral lines. This practice saves installation time, reduces fitting inventory costs, and in most cases will not present any problems as long as the installer does not exceed the maximum flow rate for the size of the pipe used.

The larger the project however, the more important it becomes to manage the system's friction losses. When installing larger systems, sizing all lateral lines the same can be quite wasteful. The material costs are higher, and the amount of water required to fill an over-sized pipe, which is then lost to low head drainage, can be significant.

Here, we are going to discuss pipe sizing so that you are familiar with the procedure. Many times when a sprinkler is not performing according to manufacturer's specifications, it is because of improper pressure or flow. Correct pipe sizing will uncover potential pressure or flow problems in sprinkler systems.

When sizing pipes, you can use the friction loss tables developed from the Hazen-Williams formula, or you can use the Friction Factor formula.

Pipe Sizing Using the Friction Loss Tables

Lateral Lines. Refer to the Hunter Friction Loss Tables in the back of this Design Manual and begin sizing the pipe:

1. Start at the head furthest from the zone valve. The pipe connecting the last head to the second to the last head should be 3/4". (It is acceptable to use 1/2" PVC pipe, but do so with caution; watch the sprinkler's flow requirements.)
2. Add the GPM requirements of the last head and the second to the last head together to size the next pipe.
3. On the Friction Loss Table for the type of pipe you have designed, find the GPM total from step 2 in the far left column.
4. On that row, go across to the first column that is not shaded*. At the top of this column is the pipe size necessary to carry the flow for these two heads.
5. Add the GPM requirements of the next head to the last GPM total.
6. Find this total in the Friction Loss Tables.
7. Continue to do this until you get to the zone valve. Do not try to size a pipe smaller than the chart indicates.
8. Repeat steps 1 through 7 for each zone.

Main Lines. Refer to the Hunter Friction Loss Tables for sizing the main line. The main line should be sized large enough to handle the requirements of the zone valves it is serving; use the zone with the largest flow requirements. (Note: This assumes only one valve will be operating at one time on an automatic system.)

*Note: The shaded area on the chart designates those flow rates that exceed 5 fps. It is recommended that caution be used with flow rates exceeding 5 fps in pipes.

Pipe Sizing Using the Friction Factor Formula

The Friction Factor formula is used to determine the maximum flow in gallons per minute through any section of lateral line pipe while not exceeding a predetermined pressure loss variation. In order to minimize uneven distribution, sprinklers on a zone should operate with pressure variation between sprinklers of not more than 10% to 20 % of the desired sprinkler operating pressure.

$$\text{Friction Factor} = \frac{\text{sprinkler operating pressure} \times \text{allowable \% of PSI variation}}{\text{critical length of pipe from the valve to the furthest head (in hundreds of feet)}}$$

Once the acceptable PSI loss has been calculated, refer to the Hunter Friction Loss Tables to size the pipe.

1. Beginning with the smallest sized pipe on the friction loss chart for the pipe you are using, locate the calculated Friction Factor under the column labeled "P.S.I. LOSS"
2. Now go across the row at this point to the left hand column to find how much water should be allowed to flow through this size pipe.
3. Repeat step one and step two for all sizes of pipe until you have reached your design capacity.
4. Starting at the head furthest from the zone valve, begin sizing the pipe based on the numbers obtained in steps 1 through 3. The pipe connecting the last head to the second to the last head should be 3/4". (It is acceptable to use 1/2" PVC pipe, but do so with caution; watch the sprinkler's flow requirements.)
5. Add the GPM requirements of those two heads together, and note how it compares to the allowable GPM in steps 1 through 3.
6. Add the GPM requirements of the next head to the last GPM total. Again note how the total GPM requirement compares to the allowable GPM in steps 1 through 3.
7. Continue to do this until you get to the zone valve. Do not try to size a pipe smaller than the Friction Formula indicates.
8. Repeat steps 4 through 7 for each zone.

The Friction Factor formula is the most accurate method of pipe sizing, and will provide the most uniform application of water. Hunter's Handbook of Technical Irrigation Information (LIT-194) has a section titled Friction Factor Short Cuts. In this section, pipe sizing charts are provided for various types of pipe and Friction Factors.

Hunter[®]

Backflow Preventer and Valve Sizing

Backflow preventers and automatic control valves can be large pressure consumers. Sizing these valves is easy – simply use the manufacturer’s pressure loss charts. Isolation valves can be great tools if valve maintenance is necessary, and are mandatory for winterization if the system is installed in freezing climates.

Backflow Preventers

Backflow preventers are generally sized the same size as, or one size smaller than the mainline. Check the pressure loss chart in the manufacturer’s product catalog to be sure it is not sized too small. Use caution when sizing backflow preventers. If they are sized too small, high friction losses may occur.

Isolation Valve Sizing

Isolation valves (gate valves or ball valves) should be line size. In other words, if the main line is 1”, the isolation valve should be 1”; if the main line is 1-1/4”, the isolation valve should be 1-1/4”.

Automatic Zone Control Valve Sizing

Size automatic control valves according to the zone flow rate requirements. Generally speaking, automatic control valves can be sized as small as one size smaller than the lateral line it is serving. Check the pressure loss chart in the product catalog to be sure it is not sized too small. Use caution when sizing control valves. If the valves are sized too small, high friction losses are inevitable, and water hammer is likely.

Summary

When designing a system it is important to stay within the system's design capacity and working pressure as calculated in the Design Capacity section. Trying to use more water than is available will result in a system that will not perform efficiently.

The majority of new system failures is a direct result of not designing to the volume and pressure available. By not exceeding the system's design capacity when circuiting the sprinklers into zones, and staying within the allowable friction loss when sizing pipe and valves, the system's performance will be just as you expected when you began your design.

What You Need to Know

Divide the individual areas into zones so that the design capacity is not exceeded; don't place too many heads on the same zone.

When backflow preventers, valves, or pipe are sized too small, the system may experience water hammer. Severe water hammer will cause the pipes to vibrate or create a pounding noise. In extreme conditions, damage to the system may occur.

When the components are sized too large, the initial cost of the system is higher than necessary. Automatic control valves which are sized too large may not close due to the slow moving water.

Follow the pipe sizing instructions in this section on page 109 (using the Hunter Friction Loss Tables), or on page 110 (using the Friction Factor formula). For fast small-system pipe sizing, you can use the following chart. The pipe sizes for this chart are based on flow rates of five feet per second.

PIPE SIZING CHART			
Maximum Flow Rates For Sprinkler Pipes			
Pipe Size	PVC Schedule 40	PVC Class 200	Polyethylene Pipe
3/4 in.	8 GPM	10 GPM	8 GPM
1 in.	13 GPM	16 GPM	13 GPM
1 1/4 in.	23 GPM	26 GPM	23 GPM

Figure 44

Friction Losses

Introduction

Calculating the friction losses on your design is a critical step in providing an accurately completed plan. In the Design Capacity section, we estimated how much pressure would be available at a particular flow. In the System Layout section, those estimates were used to design the system. This system design establishes the actual flow that will be used to water the landscaped area. But remember, the system was designed using estimates; the plan must be checked to verify that the sprinkler system will operate as designed.

Excessive friction losses results in a system that may not work efficiently, or a system that may fail in the future due to pressure changes occurring in the neighborhood. This section will lead you through the process of checking the design to make sure that the friction losses will not be excessive.

Most Critical Zone

While checking the friction losses for each zone on the plan is a good idea, it is not always a requirement. For example, if one zone on the property has a 15 GPM flow rate, it may not be necessary to check the zone with a flow rate of 10 GPM.

If, however, the 10 GPM zone is several feet higher than the 15 GPM zone, then it would be wise to check the friction losses on that zone as well. Additionally, the zone with the highest flow rate may not be the furthest away from the POC, and as previously discussed, distance is a factor in friction losses.

So, when deciding which zone is the most critical zone for calculating friction losses, consider the following factors:

- the most GPM, or highest flow rate
- highest head(s)
- furthest distance from the POC

This may mean that the friction losses must be calculated on several, or all of the zones.

Calculating Friction Losses

Using the completed plan with the sprinkler's GPM requirements marked at each head location, and the Friction Loss Tables located in the back of this design manual, begin calculating the PSI losses on the critical zones. Calculate one zone at a time.

PSI Losses in Lateral Line Pipe

Turn to the Hunter Friction Loss Tables in the back of this design workbook for the type of lateral line pipe used in the design. On the plan, note the GPM requirement for the last head on the zone that you have chosen to calculate.

1. Look in the "FLOW G.P.M." column on the friction loss chart and read down to the GPM for the last head.
2. Now, read across the top of the chart looking for the size of the pipe that supplies water to this head.
3. Read down this column, under the "P.S.I. LOSS" heading, and across the row for the GPM (6 GPM)
4. Where the two intersect is the PSI loss per 100 feet of pipe. Divide this number by 100 for the pressure loss per foot.

5. Multiply your answer by the length of pipe supplying this sprinkler only (just to the next head on the zone).
6. Write this number down.

On the plan, note the GPM requirement for the next to the last head on the zone which you have chosen to calculate. Add the two GPM rates together (the last head and the next to the last head). This number is the amount of water that will flow through the next length of pipe. Repeat steps 1 - 6 to calculate the friction loss for this section of pipe.

Repeat this process for all lengths of pipe on the zone back to the valve.

Losses Through Main Line Pipe

Continuing toward the POC, use the total GPM for the zone, and calculate the friction losses in the main line. Don't forget, you may have changed the type of pipe for the main line, so use the appropriate friction loss chart.

Friction Losses for Fittings

The friction losses for couplings, elbows, and tees can be high. Use the chart on page 10, in the Hunter Friction Loss Tables to figure the losses. An acceptable pressure loss figure to use if you don't want to calculate each fitting is 10% of the losses established for the pipe. It is recommended that you calculate several systems first to see if a 10% figure is accurate to your designs.

Losses Through Valves and Other Components

See the manufacturer's catalog for the friction loss through valves and other components:

- control valves
- isolation valves
- backflow preventer
- pressure regulator
- filter

Total System Losses

Add the friction losses for all of the pipe and other components all the way back to the irrigation POC. Remember to include pressure losses for elevation gain from the highest head in the system to the POC (or pressure gains for heads which are lower than the POC).

Refer back to the original calculation for design capacity and dynamic pressure. Make sure the system requirements that you just added up are within the calculated design capacity. Subtract the system's friction loss

from the dynamic pressure at design capacity at the POC (line #20 on the worksheet for metered and unmetered systems, line #17 for pump systems). Make sure the final dynamic pressure is sufficient to operate the sprinklers chosen for the project.

Repeat this process for each critical zone, and for the critical zone(s) for each different type of sprinkler chosen.

Sample Problem

Here, we will use the following simple example to calculate friction losses as we have just discussed.

Note in the example that the pipe connecting Sprinkler A and B will only supply water to Sprinkler A, while the pipe between Sprinkler D and E will supply water to four sprinklers: D, C, B, and A. In other words, each length of pipe will supply a different amount of water than the next length. Therefore, we will calculate the friction losses separately for each length of pipe.

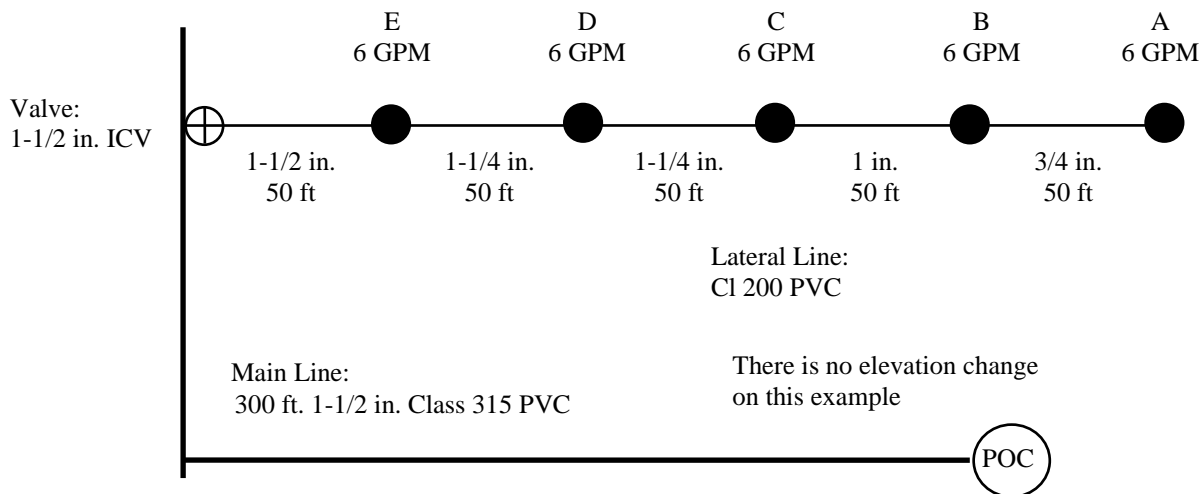

Friction Loss Calculations

Project _____

Design Capacity _____

Dynamic Pressure _____

(at Design Capacity, at the POC -

Line #20 on the Design Capacity Worksheet)

Zone Number _____

	Type of Pipe	Size of Size	GPM Flow	Loss per 100 ft.	Loss per Foot	Length of Pipe	Loss per Length
Lateral Line							
Lateral Line							
Lateral Line							
Lateral Line							
Lateral Line							
Lateral Line							
Lateral Line							
Lateral Line							
Lateral Line							
Lateral Line							
Lateral Line							
Lateral Line							
Lateral Line							
Main Line							
Main Line							
Main Line							
				Zone	Size	PSI	
				GPM		Loss	
Subtotal Pressure Losses in Pipe (above)							
Fittings - Subtotal of the Pressure Losses in Pipe _____ x 10%							
Control Valve							
Isolation Valve							
Isolation Valve							
Backflow Preventer							
Pressure Regulator							
Filter							
Miscellaneous							
Miscellaneous							
Miscellaneous							
Loss or (Gain) - Elevation							

Notes:

Total Pressure Loss

Pressure Required at the Head

Minimum Pressure Required for Sprinkler Operation as Designed

(Compare to Dynamic Pressure at Design Capacity at the POC, above)



Turn to the Hunter Friction Loss Tables located in the back of this design workbook for the type of lateral line pipe used in the design.

Sample Problem:

Class 200 PVC, page 4

Friction Loss Characteristics Class 200 IPS PVC Plastic Pipe (1120, 1220) SDR 21 C = 150 3/4" through 5" Pressure Loss per 100														
Nominal Size		3/4"		1"		1-1/4"		1-1/2"		2"		2-1/2"		
Pipe ID	Pipe OD	0.93	1.050	1.188	1.315	1.502	1.660	1.720	1.900	2.148	2.375	2.601	2.875	
Wall Thick		0.060	0.060	0.060	0.079	0.080	0.080	0.080	0.113	0.113	0.113	0.137	0.137	
Flow GPM	Velocity FPS	PSI LOSS	Velocity FPS	PSI LOSS	Velocity FPS	PSI LOSS	Velocity FPS	PSI LOSS	Velocity FPS	PSI LOSS	Velocity FPS	PSI LOSS	Velocity FPS	PSI LOSS
1	0.47	0.05	0.29	0.01	0.14	0.00	0.09	0.00	0.06	0.00	0.06	0.00	0.12	0.00
2	0.94	0.22	0.56	0.01	0.28	0.01	0.18	0.00	0.12	0.00	0.18	0.00	0.24	0.01
3	1.42	0.46	0.87	0.14	0.41	0.02	0.27	0.01	0.18	0.01	0.24	0.01	0.30	0.01
4	1.89	0.79	1.18	0.24	0.72	0.08	0.55	0.04	0.35	0.01	0.24	0.01	0.30	0.01
5	2.36	1.19	1.44	0.36	0.90	0.12	0.68	0.06	0.44	0.02	0.30	0.01	0.36	0.01
6	2.83	1.67	1.73	0.51	1.09	0.16	0.93	0.08	0.53	0.03	0.36	0.01	0.42	0.01
7	3.30	2.23	2.02	0.67	1.27	0.22	0.97	0.11	0.62	0.04	0.42	0.01	0.48	0.02
8	3.77	2.85	2.31	0.86	1.45	0.28	1.00	0.14	0.71	0.05	0.48	0.02	0.54	0.02
9	4.25	3.55	2.60	1.07	1.63	0.34	1.04	0.18	0.80	0.06	0.54	0.02	0.60	0.03
10	4.72	4.31	2.89	1.31	1.81	0.42	1.38	0.22	0.88	0.07	0.60	0.03	0.66	0.04
12	5.66	6.04	3.17	1.59	2.09	0.59	1.65	0.30	1.06	0.10	0.72	0.04	0.84	0.05
14	6.60	8.04	3.44	2.03	2.35	0.78	1.93	0.40	1.24	0.14	0.84	0.05	0.96	0.07
16	7.55	10.29	3.69	2.49	2.59	1.00	2.21	0.52	1.41	0.17	0.96	0.07	1.08	0.09
18	8.49	12.80	3.93	3.07	2.81	1.24	2.48	0.64	1.59	0.22	1.08	0.09	1.20	0.11
20	9.43	15.56	4.17	3.71	3.02	1.51	2.76	0.78	1.77	0.26	1.20	0.11	1.32	0.13
22	10.39	18.56	4.40	4.42	3.20	1.80	3.03	0.93	1.94	0.32	1.32	0.12	1.44	0.15
24	11.32	21.81	4.62	5.19	3.37	2.12	3.31	1.09	2.12	0.37	1.44	0.15	1.56	0.17
26	12.27	25.29	4.83	6.00	3.53	2.45	3.59	1.27	2.30	0.43	1.56	0.17	1.68	0.19
28	13.21	29.01	5.04	6.86	3.68	2.82	3.86	1.46	2.47	0.49	1.68	0.19	1.80	0.21
30	14.15	32.96	5.24	7.77	3.82	3.20	4.14	1.65	2.65	0.56	1.80	0.21	1.92	0.23

Figure 45

Calculate the friction losses in the pipe between Sprinklers A and B:

1. Look in the "FLOW G.P.M." column on the friction loss chart and read down to the GPM for the last head on the zone in our design (Sprinkler A).

Sample Problem:

6 GPM

2. Now, read across the top of the chart looking for the size of the pipe that supplies water to this head.

Sample Problem:

3/4 in.

3. Read down this column, under the "P.S.I. LOSS" heading, and across the row for the GPM (6 GPM).

Sample Problem:

1.67 PSI loss

4. Where the two intersect (in Step 3) is the PSI loss per 100 feet of pipe. Divide this number by 100 for the pressure loss per foot of pipe.

Sample Problem:

$$\frac{1.67}{100} = 0.0167 \text{ psi loss per ft.}$$

5. Multiply your answer by the length of pipe supplying this sprinkler only (just to the next head on the zone).

Sample Problem:

$$0.0167 \times 50 \text{ ft.} = 0.84$$

6. Write this number down.

Sample Problem:

0.84 PSI loss in the pipe
between Sprinkler A and Sprinkler B

On the example, note the GPM requirement for the next to the last head (Sprinkler B) on the zone we are calculating. Add the two GPM rates together (the last head, A, and the next to the last head, B). This total is the amount of water that will flow through the next length of pipe.

Repeat steps 1 - 6 to calculate the friction loss for this section of pipe.

Calculate the friction losses in the pipe between Sprinklers B and C:

Sample Problem:

Step 1

Sprinkler A: 6 GPM
Sprinkler B: 6 GPM
Total A/B: 12 GPM

Step 2

1 in.

Step 3

1.83 PSI loss

Step 4

$$\frac{1.83}{100} = 0.0183 \text{ psi loss per ft.}$$

Step 5

$$0.0183 \text{ PSI loss} \times 50 \text{ ft.} = 0.915$$

Step 6

0.92 PSI loss in the pipe between Sprinkler B and Sprinkler C

Calculate the friction losses in the pipe between Sprinklers C and D:

Sample Problem:

Step 1

Sprinkler A: 6 GPM
Sprinkler B: 6 GPM
Sprinkler C: 6 GPM
Total A/B/C: 18 GPM

Step 2

1-1/4 in.

Step 3

1.24 PSI loss

Step 4

$$\frac{1.24}{100} = 0.0124 \text{ psi loss per ft.}$$

Step 5

$$0.0124 \text{ PSI loss} \times 50 \text{ ft.} = 0.62$$

Step 6

0.62 PSI loss in the pipe between Sprinkler C and Sprinkler D

Calculate the friction losses in the pipe between Sprinklers D and E:

Sample Problem:

Step 1

Sprinkler A: 6 GPM
Sprinkler B: 6 GPM
Sprinkler C: 6 GPM
Sprinkler D: 6 GPM
Total A/B/C/D: 24 GPM

Step 2

1-1/4 in.

Step 3

2.12 PSI loss

Step 4

$$\frac{2.12}{100} = 0.0212 \text{ psi loss per ft.}$$

Step 5

$$0.0212 \text{ PSI loss} \times 50 \text{ ft.} = 1.06$$

Step 6

1.06 PSI loss in the pipe between Sprinkler D and Sprinkler E

Calculate the friction losses in the pipe between Sprinklers E and the Automatic Control Valve:

Sample Problem:

Step 1

Hunter®

Sprinkler A: 6 GPM
Sprinkler B: 6 GPM
Sprinkler C: 6 GPM
Sprinkler D: 6 GPM
Sprinkler E: 6 GPM
Total A/B/C/D/E: 30 GPM

Step 2

1-1/2 in.

Step 3

1.66 PSI loss

Step 4

$$\frac{1.65}{100} = 0.0165 \text{ psi loss per ft.}$$

Step 5

$$0.0165 \text{ PSI loss} \times 50 \text{ ft.} = 0.83$$

Step 6

0.83 PSI loss in the pipe between Sprinkler E and the Valve

If the zone you have designed has more heads and lengths of pipe, simply continue this process back to the automatic control valve.

We have completed our calculations for the friction losses in the lateral line pipe back to the valve in the example on page 116, so we will now begin calculating the main line pipe losses.

Calculate the friction losses in the main line:

Continuing toward the POC, use the total GPM for the zone, and calculate the friction losses in the main line. Don't forget, you may have changed the type of pipe for the main line, so use the appropriate friction loss chart.

Sample Problem:

300 ft. 1-1/2 in. Class 315 PVC
(Hunter Friction Loss Charts, page 3)

Step 1

30 GPM

Step 2

1-1/2 in.

Step 3

2.23 PSI loss

Step 4

$$\frac{2.23}{100} = 0.0223 \text{ psi loss per ft.}$$

Step 5

$$0.0223 \text{ PSI loss} \times 300 \text{ ft.} = 6.69$$

Step 6

6.69 PSI loss in the Main Line pipe between the Valve and POC

Calculate the friction losses in the fittings:

The friction losses for couplings, elbows, and tees can be high. Use the chart on page 10, in the Hunter Friction Loss Tables to figure the losses. An acceptable pressure loss figure to use if you don't want to calculate each fitting is 10% of the losses established for the pipe. It is recommended that you calculate several systems first to see if a 10% figure is accurate to your designs.

Sample Problem:

Losses between Sprinkler A and B:	0.84 PSI
Losses between Sprinkler B and C:	0.92 PSI
Losses between Sprinkler C and D:	0.62 PSI
Losses between Sprinkler D and E:	1.06 PSI
Losses between Sprinkler E and the Valve:	0.83 PSI
Losses on the Main Line due to this zone:	<u>6.69 PSI</u>
Total losses through pipe due to this zone:	10.96 PSI

Using the acceptable 10% allowance:

$$10.96 \times 10\% = 1.096$$

PSI loss through fittings, based on 10% allowance: 1.1 PSI

Check the friction losses through the valves and other components:

See the manufacturer's catalog for the friction losses through valves and other components:

- control valves
- isolation valves
- backflow preventer
- pressure regulator
- filter

Sample Problem:

30 GPM flows through this zone control valve.

The zone control valve is an 1-1/2 Hunter ICV.

In the Hunter catalog on page 21, is the ICV pressure loss chart.

Find 30 GPM in the left hand column of the blue chart.

Locate the column for the 1-1/2 in. valve.

Where the 30 GPM row intersects the 1-1/2 in. column is the **pressure loss through the valve: 1.5 PSI**

There are no isolation valves on this system.

We will not calculate the friction loss for the backflow preventer in this example.*

There is no pressure regulator or filter in this example.

*Note: friction losses through backflow preventers can be substantial - always include the friction loss for the backflow in your calculations.

Add up all of the losses you have just calculated:

Add the friction losses for all of the pipe and other components all the way back to the irrigation POC. Remember to include pressure losses for elevation gain from the highest head in the system to the POC (or pressure gains for heads which are lower than the POC).

Sample Problem:

Total losses through pipe due to this zone:	10.96 PSI
Total PSI loss through fittings	1.10 PSI
Total PSI loss through valves	1.50 PSI
Total PSI loss through elevation change	0.00 PSI
Total losses for this zone:	13.56 PSI

Hunter®

Check to be sure that the PSI losses do not exceed the available PSI for the system.

Refer back to the original calculation for design capacity and dynamic pressure. Make sure the system requirements that you just added up are within the calculated design capacity. Subtract the system's friction loss from the dynamic pressure at design capacity at the POC (line #20 on the Design Capacity worksheet for metered and unmetered systems, line #17 for pump systems). Make sure the final dynamic pressure is sufficient to operate the sprinklers chosen for the project.

Many designers will add the PSI requirement for the sprinkler to the total PSI losses. (For instance: if the operating pressure for the head in our example is 50 PSI, then you would add 50 PSI to the 13.56 PSI loss calculated, for a total of 63.56 minimum PSI requirement.)

Total losses for this zone:	13.56 PSI
Operating pressure required for head	<u>50.0 PSI</u>
Minimum PSI requirement for system	63.56 PSI

If the dynamic pressure at design capacity at the POC (line #20 on the Design Capacity worksheet) is 70 PSI, then you have sufficient pressure to operate this system.

If however, the pressure on your Design Capacity worksheet is 60 PSI, then you will need to resize the pipe, valves, and/or other components, or reduce the number of heads in order to lower the friction losses through the system.

Repeat this friction loss calculation process for each critical zone, and for the critical zone(s) for each different type of sprinkler chosen.

Summary

Calculating the friction losses for each zone may not be necessary, but calculating the losses for each *critical* zone is. This step may be the difference between a system that works efficiently after installation, and one that doesn't work at all.

Catching a mistake while in the design process means simply redesigning the system. Finding a mistake during installation which causes the addition of zones not included in the estimate can mean lost profits. And worse yet, being called back onto a project with a sprinkler system that fails shortly after completion can be very costly.

Calculating the actual dynamic pressure as designed is an important part of the design process. The more accurate the design and the friction loss calculations, the more likely the system will operate efficiently.

What You Need to Know

- Check to be sure that the PSI losses on your designs do not exceed the available PSI for the system (see line #20, Dynamic Pressure at Design Capacity, at the POC, in the Design Capacity section).
- If the pressure losses do exceed the available dynamic pressure, resize the pipe, valves, and other components as necessary.
- After resizing, be sure to recalculate the system's friction losses.
- If resizing does not bring the system into the correct operating pressure, you may need to eliminate heads from the zones, and add more zones.
- Friction Loss Calculations worksheets are included (next few pages) to make these calculations easier for you.

Friction Loss Calculations

Project _____

Design Capacity _____

Dynamic Pressure _____

(at Design Capacity, at the POC -

Line #20 on the Design Capacity Worksheet)

Zone Number _____

	Type of Pipe	Size of Size	GPM Flow	Loss per 100 ft.	Loss per Foot	Length of Pipe	Loss per Length
Lateral Line							
Lateral Line							
Lateral Line							
Lateral Line							
Lateral Line							
Lateral Line							
Lateral Line							
Lateral Line							
Lateral Line							
Lateral Line							
Lateral Line							
Lateral Line							
Main Line							
Main Line							
Main Line							
				Zone	Size	PSI	
				GPM		Loss	
Subtotal Pressure Losses in Pipe (above)							
Fittings - Subtotal of the Pressure Losses in Pipe _____ x 10%							
Control Valve							
Isolation Valve							
Isolation Valve							
Backflow Preventer							
Pressure Regulator							
Filter							
Miscellaneous							
Miscellaneous							
Miscellaneous							
Loss or (Gain) - Elevation							

Notes:

Total Pressure Loss

Pressure Required at the Head

Minimum Pressure Required for Sprinkler Operation as Designed

(Compare to Dynamic Pressure at Design Capacity at the POC, above)



Friction Loss Calculations

Project _____

Design Capacity _____

Dynamic Pressure _____

(at Design Capacity, at the POC -

Line #20 on the Design Capacity Worksheet)

Zone Number _____

	Type of Pipe	Size of Size	GPM Flow	Loss per 100 ft.	Loss per Foot	Length of Pipe	Loss per Length
Lateral Line							
Lateral Line							
Lateral Line							
Lateral Line							
Lateral Line							
Lateral Line							
Lateral Line							
Lateral Line							
Lateral Line							
Lateral Line							
Lateral Line							
Lateral Line							
Lateral Line							
Main Line							
Main Line							
Main Line							
				Zone	Size	PSI	
				GPM		Loss	
Subtotal Pressure Losses in Pipe (above)							
Fittings - Subtotal of the Pressure Losses in Pipe _____ x 10%							
Control Valve							
Isolation Valve							
Isolation Valve							
Backflow Preventer							
Pressure Regulator							
Filter							
Miscellaneous							
Miscellaneous							
Miscellaneous							
Loss or (Gain) - Elevation							

Notes:

Total Pressure Loss

Pressure Required at the Head

Minimum Pressure Required for Sprinkler Operation as Designed
(Compare to Dynamic Pressure at Design Capacity at the POC, above)



Friction Loss Calculations

Project _____

Design Capacity _____

Dynamic Pressure _____

(at Design Capacity, at the POC -

Line #20 on the Design Capacity Worksheet)

Zone Number _____

	Type of Pipe	Size of Size	GPM Flow	Loss per 100 ft.	Loss per Foot	Length of Pipe	Loss per Length
Lateral Line							
Lateral Line							
Lateral Line							
Lateral Line							
Lateral Line							
Lateral Line							
Lateral Line							
Lateral Line							
Lateral Line							
Lateral Line							
Lateral Line							
Lateral Line							
Main Line							
Main Line							
Main Line							
				Zone	Size	PSI	
				GPM		Loss	
Subtotal Pressure Losses in Pipe (above)							
Fittings - Subtotal of the Pressure Losses in Pipe _____ x 10%							
Control Valve							
Isolation Valve							
Isolation Valve							
Backflow Preventer							
Pressure Regulator							
Filter							
Miscellaneous							
Miscellaneous							
Miscellaneous							
Loss or (Gain) - Elevation							

Notes:

Total Pressure Loss

Pressure Required at the Head

Minimum Pressure Required for Sprinkler Operation as Designed
(Compare to Dynamic Pressure at Design Capacity at the POC, above)



Friction Loss Calculations

Project _____

Design Capacity _____

Dynamic Pressure _____

(at Design Capacity, at the POC -

Line #20 on the Design Capacity Worksheet)

Zone Number _____

	Type of Pipe	Size of Size	GPM Flow	Loss per 100 ft.	Loss per Foot	Length of Pipe	Loss per Length
Lateral Line							
Lateral Line							
Lateral Line							
Lateral Line							
Lateral Line							
Lateral Line							
Lateral Line							
Lateral Line							
Lateral Line							
Lateral Line							
Lateral Line							
Lateral Line							
Lateral Line							
Main Line							
Main Line							
Main Line							
				Zone	Size	PSI	
				GPM		Loss	
Subtotal Pressure Losses in Pipe (above)							
Fittings - Subtotal of the Pressure Losses in Pipe _____ x 10%							
Control Valve							
Isolation Valve							
Isolation Valve							
Backflow Preventer							
Pressure Regulator							
Filter							
Miscellaneous							
Miscellaneous							
Miscellaneous							
Loss or (Gain) - Elevation							

Notes:

Total Pressure Loss

Pressure Required at the Head

Minimum Pressure Required for Sprinkler Operation as Designed

(Compare to Dynamic Pressure at Design Capacity at the POC, above)



Friction Loss Calculations

Project _____

Design Capacity _____

Dynamic Pressure _____

(at Design Capacity, at the POC -

Line #20 on the Design Capacity Worksheet)

Zone Number _____

	Type of Pipe	Size of Size	GPM Flow	Loss per 100 ft.	Loss per Foot	Length of Pipe	Loss per Length
Lateral Line							
Lateral Line							
Lateral Line							
Lateral Line							
Lateral Line							
Lateral Line							
Lateral Line							
Lateral Line							
Lateral Line							
Lateral Line							
Lateral Line							
Lateral Line							
Lateral Line							
Main Line							
Main Line							
Main Line							
				Zone	Size	PSI	
				GPM		Loss	
Subtotal Pressure Losses in Pipe (above)							
Fittings - Subtotal of the Pressure Losses in Pipe _____ x 10%							
Control Valve							
Isolation Valve							
Isolation Valve							
Backflow Preventer							
Pressure Regulator							
Filter							
Miscellaneous							
Miscellaneous							
Miscellaneous							
Loss or (Gain) - Elevation							

Notes:

Total Pressure Loss

Pressure Required at the Head

Minimum Pressure Required for Sprinkler Operation as Designed
(Compare to Dynamic Pressure at Design Capacity at the POC, above)



Precipitation Rates

Introduction

Today's irrigation designer or system manager faces a multitude of concerns including:

- increased costs for water
- higher bills for pumping
- excessive runoff
- too much or too little water applied
- wet spots that do not allow use of a turf or landscape
- dry spots that are unsightly or cause lost plant material
- increased pests and diseases

Each of these concerns can be related to precipitation rates. Thus, understanding precipitation rates can help you avoid these common problems, leading to improved landscapes and reduced costs through better irrigation design and management.

What Is “Precipitation Rate?”

If someone said they were caught in a rainstorm that dropped one inch of water in an hour you would have some idea of how “hard” or “heavily” the rain came down. A rainstorm that covers an area with one inch of water in one hour has a “precipitation rate” of one inch per hour (1 in./hr). Similarly, if a sprinkler system applies enough water to cover the irrigated area with one inch of water in one hour, the sprinkler system also has a precipitation rate of 1 in./hr. Thus, the precipitation rate is the speed at which a sprinkler or an irrigation system applies water.

Are All Precipitation Rates the Same?

Landscape irrigation systems and individual sprinklers themselves have widely varying precipitation rates. The rates typically vary from:

- Low – 0.5 in./hr and below
- Medium – 0.5 to 1.0 in./hr
- High – 1.0 in./hr and above

These precipitation rates reflect the typical soil infiltration rates. Use of sprinklers with high precipitation rates on soils with low infiltration rates would result in excessive runoff.

Sprinkler Type and Expected Precipitation Rate

While the correlation between sprinkler type and precipitation rate is not absolute, the following chart provides a general indication of the precipitation rates you can expect with different types of sprinkler heads.

As you can see, sprinklers may fall into more than one category.

TYPICAL PRECIPITATION RATE RANGES

	LOW	MODERATE	HIGH	
BUBBLERS			1-1/2 to	12 in./hr.
FIXED SPRAYS			1 to 5 in./hr.	
GEAR DRIVE ROTORS	0.1 to	1.0 in./hr.		
	0.1	1.0	2.0	

Figure 46

High Precipitation Rates – More than 1.0 in./hr

Sprinklers with these precipitation rates would be best suited for use on level, coarse-textured soils with high infiltration rates and little hazard of erosion. If used in other conditions they must be operated in short cycles to avoid excessive runoff and soil erosion.

Moderate Precipitation Rates – Between 0.5 and 1.0 in./hr

Sprinklers with these precipitation rates should be used under conditions similar to those described for high precipitation-rate sprinklers. However, these could be operated for somewhat longer cycles than the high precipitation-rate heads.

Low-Precipitation Rates – 0.5 in./hr or Less

Low precipitation-rate sprinklers have the advantage in that they can be used with a wider variety of slope and soil textures without excessive runoff or soil erosion.

Sprinkler Precipitation Rates

Versus System Precipitation Rates

Depending on the construction of the irrigation system, the precipitation rate may be quoted as either a “sprinkler” or a “system” rate.

The precipitation rate of a system is inversely related to head spacing and row spacing. With the sprinkler flow rate remaining the same, **increasing** head or row spacing **decreases** the precipitation rate while **reducing** head or row spacing **increases** the precipitation rate.

Sprinkler Precipitation Rates

The precipitation rate for a “sprinkler” refers to the rate for a system in which only one specific type of head and nozzle is used. The precipitation rate for a single sprinkler is calculated using the **Sprinkler Spacing Method**. This method calculates the precipitation rate for those sprinkler heads with the same spacing, rate of flow (in gallons per minute, or GPM) and arc of spray.

System Precipitation Rates

The precipitation rate for a “system” is the average precipitation rate of all sprinklers in an area regardless of the arc, spacing, or flow rate for each head. The system precipitation rate is calculated using the **Total Area Method**. The area for which the calculation is made usually corresponds to all the heads on one irrigation control valve, but can include many valves in an area. While individual heads in an area may have different precipitation rates, this method gives you an *average* over the entire area.

The Total Area Method is most useful and accurate when all the heads in the area have similar precipitation rates. Where the precipitation rates of the sprinkler heads vary considerably, the average precipitation rate can be misleading. Where there are differences in precipitation rates, the irrigation system may have applied enough water to the “average” area, but there very likely will be dry spots and wet spots as well.

Note: It is important to remember that precipitation rates and system uniformity are two completely separate issues. Calculated precipitation rates do not reflect how uniformly the water is being applied. System uniformity is an important variable and should always be taken into account when scheduling irrigation systems or determining minimum water supply requirements.

Matched Precipitation Rates

A system or zone in which all the heads have similar precipitation rates is said to have matched precipitation rates. A sprinkler by itself does not have a matched precipitation rate. Only when it is used with other sprinklers of similar precipitation rates would they be considered matched (matched implies two or more). When designing sprinkler systems, matching precipitation rates can help to avoid wet and dry spots and excessive run times which leads to high water bills, increased pumping costs, or both.

Wet and dry areas can be caused by applying water at different precipitation rates. The area with the low precipitation rate becomes a dry spot and the area with the high precipitation rate becomes too wet. Where heads that apply water at substantially different precipitation rates must be used, they should be zoned separately—divided into circuits that are operated by different control valves. Separate control zones can be used to schedule an increase in run times for lower precipitation rate heads in order to equalize the amount of water applied.

Achieving Matched Precipitation Rates

As discussed earlier, head and row spacing directly affect system precipitation rates. There are two other related factors that also affect precipitation rate: the head's arc of coverage and its flow rate in GPM. (In this section, we assume that head and row spacing remain the same.) The following diagram depicts a sprinkler with three different arcs of coverage with matched precipitation rates.

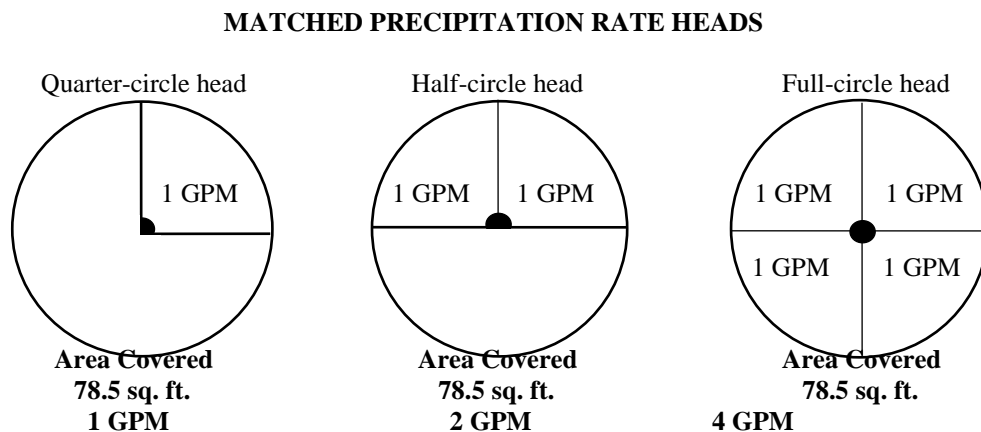

Figure 47

With matched precipitation rates, as the arc of the sprinkler increases, the flow rate also increases. In the previous illustration, the half-circle head covers twice the area of the quarter-circle head, with a flow rate twice that of the quarter-circle head. The full-circle head covers twice the area of the half-circle head and four times the area of a quarter-circle head, and has a flow rate twice that of the half-circle head and four times that of the quarter-circle head.

If the heads in the example all have a 10-ft radius, the arc, area covered, and rate of flow for each would be:

Arc	Area Covered by Sprinkler	Flow
90°	78.5 sq. ft	1 GPM
180°	157 sq. ft	2 GPM
360°	314 sq. ft	4 GPM

As the spray arc doubles, so does the flow. This is a quick way to check for matching precipitation-rate heads or nozzles. The flow rate of half-circle heads must be two times the flow rate of the quarter-circle heads, and the full-circle heads must have two times the flow rate of the half-circle heads. Manufacturers' specifications often specifically indicate the sprinklers with doubling arcs and flow rates; i.e., the sprinklers considered to have matched precipitation rates. (While exact doubling of flow rates is ideal, heads with GPM values within $\pm 10\%$ of the ideal is considered to have matched precipitation rates.)

This principle can be applied to nozzle selection, as well as head selection. Sprinklers with multiple nozzle options can deliver matched precipitation rates if the installer follows the principle of doubling the flow as the arc doubles.

Proper Use of Matched Precipitation-Rate Heads

Use of matched precipitation-rate heads simplifies the design process by eliminating the need to separate full-circle heads from quarter-circle and half-circle heads.

When all heads or nozzles on one zone have the same GPM value as illustrated below, precipitation is not matched and poor coverage will result.

SPRINKLERS HEADS THAT DO NOT HAVE MATCHED PRECIPITATION RATES

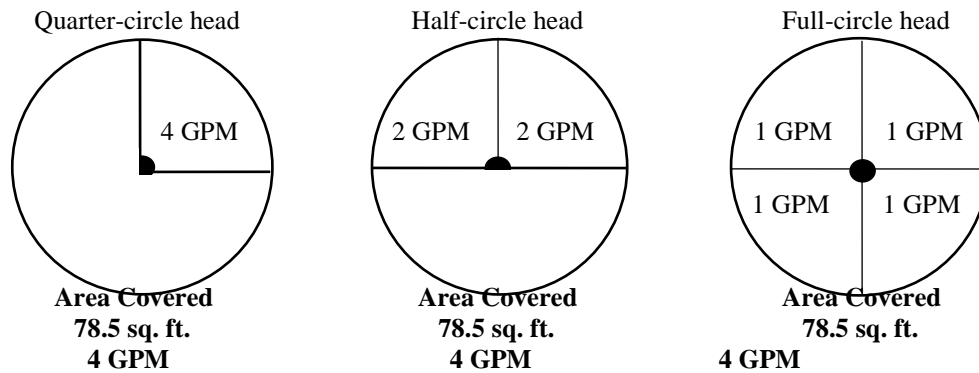

Figure 48

The area covered by the quarter-circle head is receiving four times as much water as the area covered by the full-circle head. If these heads were used on the same control valve, the areas covered by the quarter-circle heads would be too wet or the areas covered by the full-circle heads would be too dry. The use of sprinkler heads on the same valve with widely varying precipitation rates results in poor distribution uniformity and low system efficiency.

The Dry Spot Drives the System

When heads that do not have matched precipitation rates are used in the same zone, dry spots develop, and dry spots usually lead to lengthening of sprinkler run times. Since most turf managers or home owners are reluctant to allow dry areas of their lawn to die, the entire area is watered longer to ensure that sufficient water is applied to keep the dry spot alive.

Determining Precipitation Rates

As mentioned earlier, there are two primary methods used to determine the precipitation rate: the Sprinkler Spacing Method and the Total Area Method.

The Sprinkler Spacing Method

This method is used to determine the precipitation rate for a single sprinkler. The rate is calculated assuming the sprinkler is used in conjunction with other sprinklers of the same kind (i.e., same arc, flow, and spacing). With this method, one can compare the precipitation rate of similar types of sprinkler heads with each other.

The following Sprinkler Spacing Method formula is applicable to heads of any arc.

$$P_r = \frac{34650 \times \text{GPM (for any arc)}}{\text{Degrees of Arc} \times \text{Head Spacing} \times \text{Row Spacing}}$$

Where:

P_r is the precipitation rate in inches per hour.

34650 is a constant that converts gallons per minute to inches per hour for sprinklers with any arc. It is derived from 60 min/hr divided by 7.48 gallons per cu ft, multiplied by 12 in. per ft times 360 degrees. (Note: If the flow of the head is in *gallons per hour* (GPH), instead of gallons per minute (GPM), the constant should be changed to 577.5).

GPM is the rated flow of the head used, regardless of its arc, in gallons per minute.

Degrees of Arc is the arc of the spray pattern, in degrees, for the sprinkler selected (full circle = 360°, half circle = 180°, etc.).

Head Spacing is the distance in feet between heads in the same row.

Row Spacing is the distance in feet between the rows of sprinklers.

While this information is helpful when comparing the precipitation rate of similar types of sprinkler heads with each other, extreme caution should be exercised when using the manufacturer's published precipitation rate information for a single sprinkler.

1. Often these are calculated for different degrees of arc (e.g. 360° vs. 180°) from manufacturer to manufacturer.
2. The manufacturer's stated precipitation rate is calculated at an exact pressure and spacing. Most layouts have specific conditions that are different from one job to another.

We recommend you always calculate the precipitation rate for your situation using the Total Area Method.

Hunter[®]

The Total Area Method

This calculation is best suited for determining the average precipitation rate for a system, or portion of a system, that uses sprinklers with differing arcs, flow rates, and spacings. The formula for the Total Area Method is:

$$P_r = \frac{96.25 \times \text{Total GPM}}{\text{Total Area}}$$

Where:

P_r is the precipitation rate in inches per hour.

96.25 is a constant that converts gallons per minute to inches per hour. It is derived from 60 min/hr divided by 7.48 gallons per cu ft times 12 inches per foot.

Total GPM is the cumulative flow from all sprinklers in the specified area, in gallons per minute.

Total Area is the area irrigated, in square feet.

Example Problem

- 12 sprinkler heads
- Arcs varying from 90° to 360°
- Flow from 2.0 to 8.0 GPM

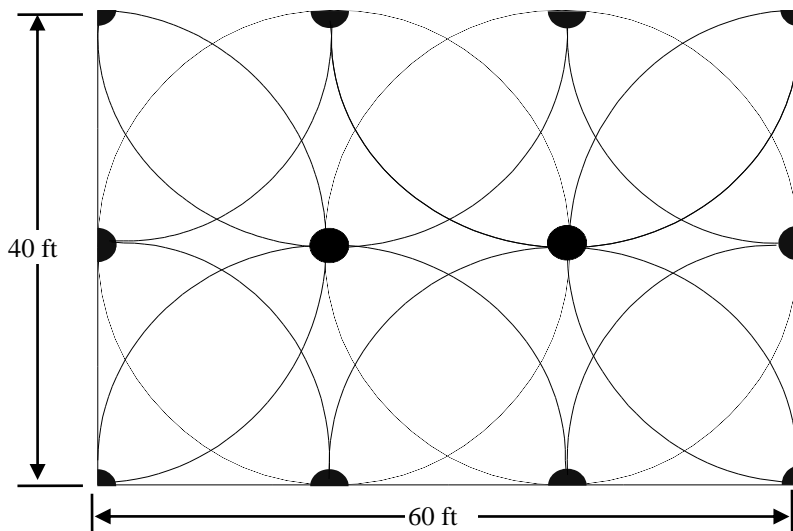

Total gpm

2 Full circle x 8.0 gpm	= 16 gpm
6 Half circle x 4.0 gpm	= 24 gpm
4 Quarter circle x 2.0 gpm	= <u>8 gpm</u>
Total	48 gpm

Total Area

40 ft x 60 ft = 2400 sq ft

$$P_r = \frac{96.25 \times 48 \text{ GPM}}{2400 \text{ sq ft}} = 1.93 \text{ in/hr}$$

Use of Precipitation Rates in Landscape Irrigation

Precipitation rate is critical to the selection of sprinkler heads for a system and scheduling sprinkler run times.

When selecting sprinkler heads, it is necessary to limit the amount of water applied to the infiltration rate of the soil. The infiltration rate is affected by the soil texture, soil structure, plant material, and the slope. Failure to limit the amount of water applied to the infiltration rate of the soil can result in excessive runoff and erosion. Matching the amount of water applied to the soil's infiltration rate can be done either by selecting a sprinkler according to its precipitation rate or by scheduling the sprinkler system's run time.

This concept will be further discussed in the section on Irrigation Scheduling.

Precipitation Rate versus Sprinkler Run Time. As previously stated, the amount of time required to irrigate a project is not typically affected by the sprinkler precipitation rate. While it is true that lower precipitation rate heads must be run for a longer periods of time, more heads can be installed on a zone and, therefore, the total irrigation time for an entire project will be the same for high precipitation-rate heads with many zones, and low precipitation-rate heads with few zones.

Similar run times can be confirmed by checking the design capacity. If designs with both high and low precipitation-rate heads use the maximum flow rate available for the project (design capacity) then both projects will have similar total run times.

Summary

Scheduling sprinkler run times without knowing the precipitation rate is like trying to estimate your arrival time without knowing how fast you are traveling. The precipitation rate represents the speed at which an amount of water is applied. Knowing this is important because it helps us estimate how long it will take to apply the water needed by the plants in the landscape. The precipitation rate is also required for proper irrigation scheduling to prevent dry or wet areas. If the precipitation rate is not known, the tendency is to over water to be sure enough water is applied.

What You Need to Know

- Precipitation rate, measured in inches per hour (in./hr.), is the speed at which a sprinkler or an irrigation system applies water.
- Matched precipitation means that all of the sprinklers on one zone have similar precipitation rates. In other words, as the arc of a sprinkler increases, the flow should increase proportionally.
- The formula for determining the precipitation rate for a given area is:

$$P_r = \frac{96.25 \times \text{Total GPM}}{\text{Total Area}}$$

Irrigation Scheduling

Introduction

Ultimately, the goal of the landscape manager is to apply only the amount of water needed, and to apply that water only when it is needed. Plants have an effective root zone (RZ), and water in the soil below that root zone is unusable by the plants. The effective root zone for turf grass, for instance, is about six inches to a foot deep.

A basic truth of plant irrigation is this: Irrigation is not meant to water the plants; rather, it is meant to refill the reservoir from which those plants will draw the water they need. If the reservoir gets too “empty,” the plants begin to wilt. When they are deprived of water for too long, a “permanent wilting point” is reached, and permanent plant damage occurs.

If the reservoir is allowed to get “too full,” the soil may reach “field capacity” at levels below the plant’s effective root zone, and water would go unused. Field capacity is the upper limit of storable water in a layer of soil after the water has drained through.

It might seem that a slow and constant supply of water would be the best way to fulfill the watering requirement. However, in most circumstances, daily watering is wasteful. Water evaporates quite rapidly from the top few inches of soil; the rate of evaporation can reach as much as 50% per day. The deeper the moisture level in the soil, the lower the daily evaporation rate.

It becomes important then, to manage the amount of water in the root zone to maximize application efficiency. When scheduling irrigation, provide enough water, at the proper times to keep the moisture level at the root zone between the permanent wilting point, and the field capacity.

Available Water Holding Capacity

This balance of moisture level in the root zone between the permanent wilting point, and the field capacity is referred to as “available water holding capacity” (AWHC), and is the water that can be used by the plants. Generally, AWHC is expressed as “inches of water available per foot of soil,” or inches/foot.

Determining How Much Water is Needed

In order to properly manage the AWHC level and program the controller with the correct watering schedule, you need just a few pieces of information:

- The amount of water needed for the turf to be healthy.
- The acceptable level of depletion of the water applied.
- The rate at which the irrigation system applies the water.
- The efficiency of the irrigation system.

With this information and some simple math, you will have the tools to properly schedule the application of water to the landscaped area.

Amount of Water Needed

Evapotranspiration Rate. The amount of water needed by a plant is the sum of the amount lost through the evaporation of moisture at the soil’s surface and the transpiration of water through the plant. The daily evapotranspiration or “ET” rate for a specific area may be available from the local extension agent or weather service, or can be determined using the approximate daily values.

Climate Type**	Daily Loss (in inches)
Cool Humid	0.10-0.15
Cool Dry	0.15-0.20
Warm Humid	0.15-0.20
Warm Dry	0.20-0.25
Hot Humid	0.20-0.30
Hot Dry	0.30-0.40

Potential Evapotranspiration Rates for Various Climates

Figure 49

* These evapotranspiration (ET) rates are approximate. Actual ET rates may be obtained from an extension agent. If the rate obtained from the agent is expressed as a monthly figure, divide the number by 30 for the average daily rate.

** “Cool” applies to areas with average high summer temperatures in mid-summer of under 70° F. “Warm” refers to mid-summer highs between 70° F and 90° F. “Hot” indicates mid-summer averages over 90° F. Areas in which the average relative humidity is over 50% in mid-summer qualify as “Humid”, while under 50% is considered “Dry”.

Crop coefficient. Different plants have specific watering requirements. The “crop coefficient” allows for the expression of this variation in moisture needs. Figure 50 provides a guide of the crop coefficients for various categories of common plants.

Vegetation Type	Coefficient
Mature Trees	0.80
Shrubs (taller than 4 ft.)	0.70
Shrubs (shorter than 4 ft.)	1.00
Warm Season Turf	0.50-0.70
Cool Season Turf	0.60-0.80

Crop Coefficient (K_C) For Common Plants
Figure 50

Acceptable Level of Depletion

Available Water Holding Capacity (AWHC). It is best to irrigate as infrequently as possible because of the high evaporation rate at the surface of the soil. Deeper, less frequent watering gets more water to the root zone. However, to avoid damage to the turf due to AWHC falling to a permanent wilting point, the turf manager must schedule irrigation run time before all of the AWHC is depleted. The acceptable level of depletion, called “Management Allowable Depletion” (MAD), can vary by soil type, compaction, root depth, and the stress tolerance of the plant. In most applications, a MAD of 50% of the AWHC will sustain healthy turf. AWHC guidelines for a few soil textural classes are as follows:

Soil Texture	Inches of Available Water Per Foot of Soil
Sandy Soils	0.50-1.00
Loamy Soils	1.00-1.75
Clay Soils	1.75-2.50

AWHC for Various Soil Textures
Figure 51

Rate at Which Water is Applied

Precipitation Rate. The “precipitation rate” (PR) for an individual sprinkler or an entire sprinkler system is the depth of water applied in a given area, expressed in inches per hour. The precipitation rate of a *sprinkler* is determined by multiplying the gallons per minute output of *that sprinkler* by a conversion factor of 96.25 (which converts cubic inches of water to inches per square foot per hour), and then dividing by the area the sprinkler covers. The precipitation rate of an *irrigation system* is found by multiplying the total gallons per minute of the *system* by 96.25 and dividing by the total area the system covers .

$$\text{PR} = \frac{\text{GPM Applied} \times 96.25}{\text{Area Covered}}$$

(Gallons per minute can be approximated using the manufacture’s published nozzle data.)

Efficiency of the Irrigation System

Application Efficiency. Application efficiency (EA) is a measure of how much of the applied water is available for use in the effective root zone. It is also an indication of how well the system was designed and installed, and how well it has been maintained. Application efficiency is determined by dividing the amount of water in the root zone by the amount of water applied.

A perfect irrigation system where all of the water sprayed out goes directly and evenly to the turf’s root zone is unachievable. In fact, while it is feasible to achieve an application efficiency (EA) rating as high as 80%, an irrigation system with an efficiency rating of 70% is considered very good. Irrigation water can be lost through excessive evaporation (watering during the heat of the day), wind drift, incorrect adjustments, improper designs, high pressure, low pressure, run-off, percolation past the effective root zone, or through the use of the wrong size nozzles or other equipment.

There are several steps and calculations needed to determine irrigation system EA. While these calculations can be very accurate, because of the effects of wind, temperature, humidity, water pressure, soil type, and root depth, EA remains an informed estimate. For general purposes, a scheduler can expect to achieve an EA of 60% to 80%.

Calculating the Irrigation Run Time

We now have all of the information necessary to schedule the application of water. The following is a recap of the values that are used in the scheduling equation:

RZ Root Zone is the effective depth of the roots, in feet.

Hunter[®]

- ET** Evaporation of soil surface water plus Transpiration of water through the plant. (Figure 49)
- K_C** Crop coefficient is the specific water requirement of the plant. (Figure 50)
- AWHC** Available Water Holding Capacity is the moisture level in the soil (expressed in inches per foot) which is above the plant's permanent wilting point, and below the soil's field capacity. (Figure 51)
- MAD** Management Allowable Depletion of water from the AWHC. (In most applications, a MAD of 50% will sustain a healthy landscape.)
- PR** Precipitation Rate is the depth of water per unit of time. (Multiply the total gallons per minute of the *system* by 96.25 and divide by the total area the system covers.)
- EA** Application Efficiency is a measure of the overall efficiency of the sprinkler system. (60% to 80%)

The frequency (F), or "Set Days To Water", is calculated using the following formula:

$$F = \frac{AWHC \times RZ \times MAD}{ET \times K_C}$$

The amount of run time (RT) or "Set Station Run Times" each watering is calculated:

$$RT = \frac{60 \times F \times ET \times K_C}{PR \times EA}$$

Example: A valve in your system is irrigating established warm season turf which is growing in a sandy loam on a slight slope. The average precipitation rate is 0.49 inches/hour. The system is located in San Marcos, CA, where the daily moisture loss (ET) to be replenished is 0.20 inches. The system application efficiency is approximately 65%.

Answer:

Watering Frequency

$$F = \frac{1.0'' \times 0.75'' \times 50\%}{0.20 \times 0.70} = \frac{1.0 \times 0.75 \times 0.50}{0.20 \times 0.70} = \frac{0.375}{0.14} = 2.68$$

The answer is a 2 or 3 day watering interval. The scheduler may decide to use a 3 day interval (water on day #1, wait day #2 and day #3, and then begin the watering interval again on the next day), and monitor the turf's condition.

Run Time per Frequency

$$RT = \frac{60 \times 3 \times 0.20 \times 0.70}{0.49 \times 65\%} = \frac{180 \times 0.14}{0.49 \times 0.65} = \frac{25.2}{0.319} = 79$$

Water 79 minutes each watering.

Soil Intake Rate

Soil texture will provide a general idea of the rate at which water can be absorbed without runoff. Many times, the precipitation rate and run time will be more than the soil intake rate. As the soil reservoir is refilled and reaches field capacity, the additional, or free water is pulled through the soil by gravity and capillary action. If the water is applied faster than the intake rate, the water will run off and be wasted, and may cause damage to the landscaped area.

In order to determine if the watering run time must be cycled into multiple run times, look at the system's precipitation rate and compare it to the rate in Figure 52.

SOIL TEXTURE	SOIL INTAKE RATES (inches per hour)							
	0 to 5% slope		5 to 8% slope		8 to 12% slope		12%+ slope	
	Cover	Bare	Cover	Bare	Cover	Bare	Cover	Bare
Coarse sandy soils	2.00	2.00	2.00	1.50	1.50	1.00	1.00	0.50
Coarse sandy soils over compact subsoils	1.75	1.50	1.25	1.00	1.00	0.75	0.75	0.40
Uniform light sandy loams	1.75	1.00	1.25	0.80	1.00	0.60	0.75	0.40
Light sandy loams over compact subsoils	1.25	0.75	1.00	0.50	0.75	0.40	0.50	0.30
Uniform silt loams	1.00	0.50	0.80	0.40	0.60	0.30	0.40	0.20
Silt loams over compact subsoil	0.60	0.30	0.50	0.25	0.40	0.15	0.30	0.10
Heavy clay or clay loam	0.20	0.15	0.15	0.10	0.12	0.08	0.10	0.06

Soil Intake Rates for Various Soil Textures

Figure 52

The maximum precipitation-rate values listed are as suggested by the United States Department of Agriculture. The values are average and may vary with respect to actual soil conditions and condition of the ground cover.

In the previous example, the precipitation rate was calculated as 0.49 inches per hour. Comparing that to the soil intake chart, you can see that one cycle may or may not soak into the sandy loam before runoff (depending on the severity of the slope), and the turf area in this example should be monitored. If runoff is evident, the 79 minutes should be broken into two 40 minute applications, on the same day. In some cases, it may necessary to break the run times into four 20 minute run times, etc.

Summary

Proper irrigation technique is important in developing a deep root system. Replenishing the AWHC with frequent light watering is the least desirable way to water. This method never allows the soil profile to be wetted to any depth, encouraging shallow root growth and leading to plant material which is easily damaged and dependent on frequent watering.

The best method of producing a deep root system is through cyclical watering. Deeply rooted plants are less susceptible to damage from stress due to high midsummer temperatures and evaporation rates.

Scheduling irrigation according to the process described in this section is the most efficient method of watering landscape. Once you have completed a couple of scheduling programs using the formulas found on page 145, you will find that the formulas are not as complicated as they first appear.

Many of the numbers will not change from one type of plant or one project to another. For instance, once you have determined what kind of depletion you will allow (MAD), this number becomes a constant and you can use it from one schedule to another. Or, you may discover that you are working with many plants with the same root zone depth from one job to another, so this number (RZ) could easily become a constant. Additionally, even though the evapotranspiration rate will vary daily, you may find it sufficient to change the ET number that you use in the formula only four to six times a year.

For an application formula to determine how much water to apply *each week*:

$$\text{Inches of Water per Week} = \frac{7 \times \text{ET} \times K_c}{EA}$$

To determine how long to run the zone to place that amount of water each week, divide your answer by the precipitation rate of the zone.

What You Need to Know

As previously stated, scheduling irrigation according to the process described in this section is the most efficient method of watering landscape. Watering application rates will vary with different types of plants, soil, and climates. New lawn must be kept moist, and newly transplanted shrubs need watering every day or two until established. Established plants will need deeper, less frequent watering.

The following guidelines will get you started until you can calculate the proper schedule. The run times in the chart are approximate and are based on an average precipitation rate at optimum pressure and spacing.

- A controller program consists of three pieces of information:
 - What days do you want to water.
 - What time do you want to start all zones watering.
 - How long do you want each zone to run.
- Lawns require more water each week than do most shrubs.
- Apply 1 inch of water per week on lawns in cool, non-arid climates.
- Apply 2 inches of water per week on lawns in hot, arid climates.

SPRINKLER RUN TIME SCHEDULE - OVER 7 DAYS				
Water to Apply Each Week	Spray Sprinklers	PGJ Rotors	PGP Rotors	I-20 Rotors
1 in.	40 min.	130 min.	150 min.	150 min.
2 in.	80 min.	260 min.	300 min.	300 min.

WATERING GUIDELINES	
Clay Soils - fine particles - absorbs water slowly	• program the controller with shorter run times; • increase the number of start times per day; • decrease the number of water days per week.
Loam Soils - medium sized particles - average absorption rate	• program the controller with longer run times; • program with fewer start times per week.
Sandy Soils - larger particles - absorbs water rapidly	• program the controller with shorter run times; • increase the number of start times per day; • increase the number of water days per week.